

# TREADWELL™

COMPLETE “Fit & Forget” SOLUTIONS

## Sector Guide

# PETROL & CHEMICAL



ENGINEERING THE FUTURE IN COMPOSITES

[www.treadwellgroup.global](http://www.treadwellgroup.global)

# Let Treadwell Help You Release the Power of Engineered Composites on Your Next Project

## Corrosion Resistant



- Manufactured from premium isophthalic and vinyl ester resin systems.

## Cost Savings

- Longer service life, less maintenance, and life cost savings as compared to other materials.
- Allows better and viable components into the associated framework.

## High Strength

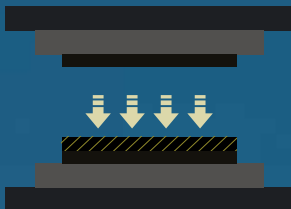

- Manufactured by automated pultrusion process.
- Utilises high glass-fibre content and results in unparalleled product consistency.
- Compression moulding and vacuum moulding processes are used.

## Turnkey Solutions



- Pre-fabricated to eliminate field fabrication and make installation quick and easy.
- Solutions include all necessary accessories.

## Customised System

- Our experienced technical team customises designs to meet project specific load requirements.

## Durability



- Highly durable.
- Greater resistance to breaks and twists which ensure better longevity.
- Reduce the harmful effects of added tension on the surface and relieving the framework.

## UV Protection

- Exterior coatings and stabilisers provide UV protection and ensure long service life.

## Low Profile

- Aesthetically pleasing flat covers.
- Eliminate confined-entry issues.
- Provide protection for equipment located on top of the cover instead of below.

## Light Weight



- Strength-to-weight properties of FRP reduce loads on tank walls and floors.
- Ease cover removability and installation.
- Can be transported anywhere easily and installed seamlessly.

## No Dissimilar Metals



- Eliminates issues surrounding dissimilar metals



## Contents

04	What You Get When You Work with Treadwell
05	Bespoke & Specialised Projects - Our Process Explained
06	Why Choose Treadwell?
08	EX-Series® FRP Grating
10	P-Series® Phenolic Grating
11	Grating Clips
12	StormChief® GRIP
13	StormChief DISC®
14	StormChief CLAW®
14	StormChief CLAMP®
15	Case Study – Subsea7
16	Case Study – Darwin LNG
17	Case Study – INPEX Darwin
18	RailEX® ROUND Tubular Handrail
19	RailEX® ROUND Overview
20	RailEX® ROUND Stanchion Kits & Handrail Parts
21	Case Study – PTTEP Australasia
22	EX-Series® Industrial Composite Solutions
23	Case Study – ExxonMobil Bass Strait
24	Case Study – Chemical Manufacturing Plant
25	EXduro™ Cable Ladders
26	Case Study – The Gorgon Project, Chevron
27	EX-Series® LadderEX® FRP Ladders
28	LadderEX® Retract-A-Stiles
29	SAFE-SERIES™ Anti-Slip Safety Solutions
30	ArchitEX™ Composite Structural FRP
31	ArchitEX™ FRP Profiles
32	TreadSLAB® Panel Types Available
33	Our Partners



### Quality Policy

Quality is at the forefront of Treadwell's working practices. With over 15 years of manufacturing to the highest quality standards, Treadwell prides ourselves on our reputation for implementing strict quality control measures, and strives to supply products that surpass customers expectations. The company works on a policy of 'continuous improvement'.



### Environment Policy

Treadwell is conscious of the impact it has on the environment and its associated responsibilities. The company is committed to ensuring its operations satisfy legal obligations and other responsibilities. Treadwell remains committed to sustainability.

**Disclaimer:** The information contained in this Treadwell design guide herein supplied is as a service to our customers and is intended to be used only as a general guide. It is not a substitute for proven engineering practices and designs.

## What You Get When You Work with Treadwell

### Specialised Online Tools

Conveniently located online, our selection tool allows users to fill in selection criteria based on each product brand we carry and will recommend a product suitable to your needs. Our product information has been imprinted on the tool to provide ease of outline and inspiration to architects, engineers, designers and other users. Users can also find all our product files in PDF, DWG, STEP etc. files to download for each of our products.

Visit our website at <https://www.treadwellgroup.com.au/treadspect/> to try out these online specifier tools.



### Friendly & Professional Design Support

Whether you're looking to upgrade or completely revamp your rail infrastructure assets, we can help support your design services across all stages of your project lifecycle. Our qualified and experienced engineering team have provided turnkey as well as purely design-based projects. With a knowledgeable team, we are able to provide solutions to fit your requirements.



### Cutting Edge Technical Information

Treadwell has a LEAN manufacturing facility, approximately 4000m<sup>2</sup> under one roof. Our automated CNC equipment, including state-of-the-art 90,000 PSI waterjet cutting system and beam line ensures minimal material wastage, and as such, eliminates excessive costs. Our internal design engineering department is able to provide design expertise and sign off engineering in all states of Australia (RPEQ and NT certified), and an on-site Quality Assurance team to perform the necessary checks.



With our well-established partnerships with logistics partners across Oceania, complemented by our own fleet of trucks and trailers in Australia, we are able to deliver your projects across the region efficiently and effectively on time and in full.

# Bespoke & Specialised Projects - Our Process Explained

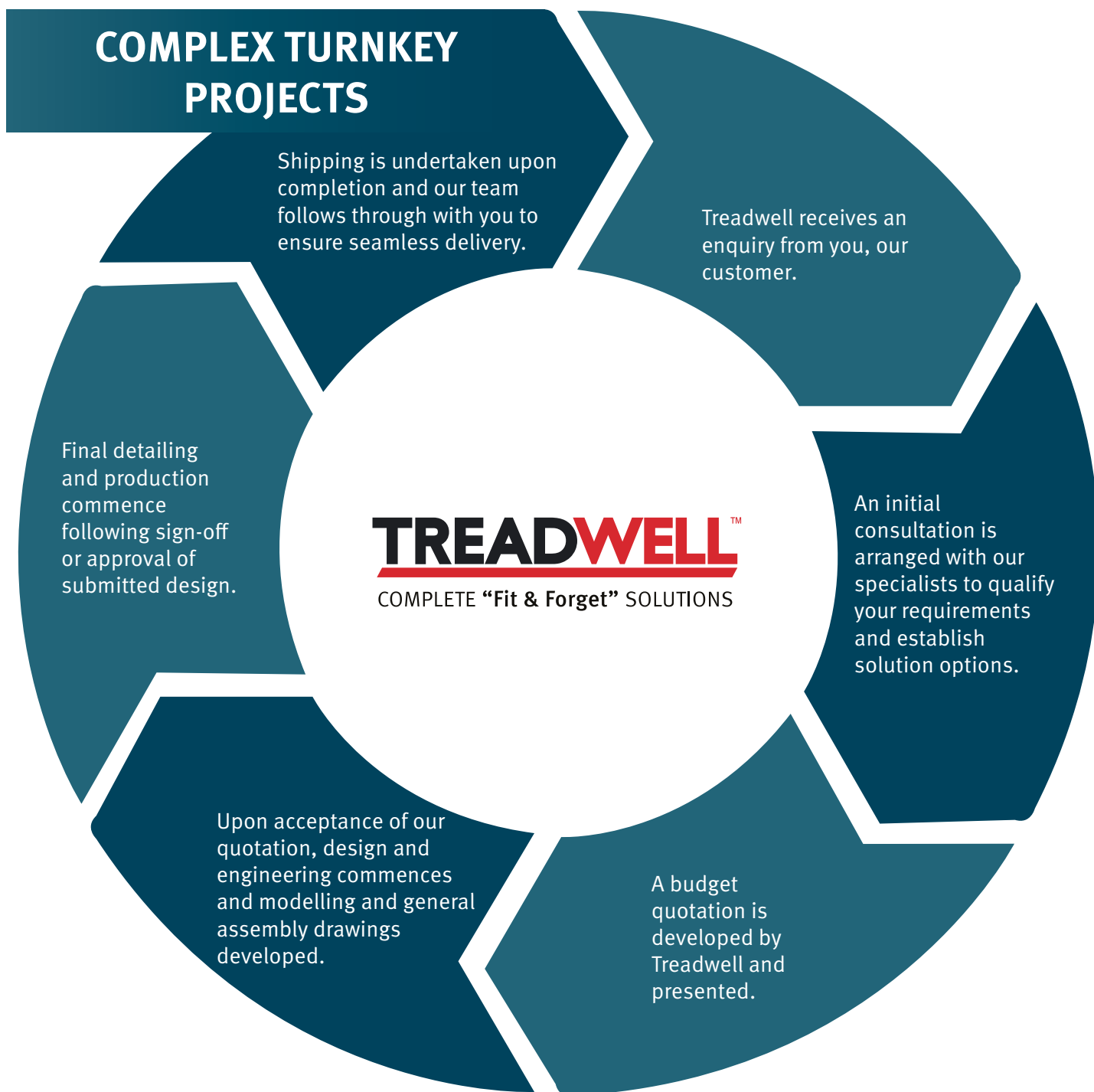

## Why Choose Treadwell?

- 1 Our team of engineers are available to support your design requirements by providing technical expertise and specifications.
- 2 Our products are tested and meet relevant compliant codes where required.
- 3 We offer solutions based on practical calculations and data, providing the optimum products for your application.
- 4 We are an established name in Australia for providing durable and dependable FRP solutions.







Images used are for illustration purposes only.



## What is EX-Series® FRP Grating?

Treadwell's GratEX® moulded FRP grating is a high strength, single piece construction mesh panel product. Treadwell offers both standard panel sizes as well as the option of custom panels made to order from your drawings, or alternatively, drawings provided by Treadwell's drafting department.

Cost effective GratEX® panels allow for effective on-site fabrication/trimming whilst ensuring that wastage is minimised. Load bearing bars in both directions allow for use without continuous side support and so contribute to cost effectiveness. GratEX® offers all the benefits available with grating made from other materials plus a host of superior benefits unequalled by steel or other metal alternatives.



### GratEX® Surface Options

**Anti-Slip Surface (Standard).** This surface is most commonly used in industrial applications. It is very hard wearing and boasts an extremely effective coefficient of friction (NATA laboratory test report available). Unlike serrated steel, the anti-slip surface does not impact load carrying capacity.

**Concave Surface.** This is preferred for environments where by-products are commonly caught by serrations, and is hence very often utilised by the food industry. This surface option can also be used for guarding options to allow safe handling/ contact.

**Plain Surface.** This is a stock option that is widely utilised for guarding and architectural features in a variety of applications. Whilst the aesthetics of the product are improved, the anti-slip properties are not as profound as the other options available.





# Treadwell EX-Series® FRP Grating

Treadwell EX-Series® Fibreglass Reinforced Plastics (FRP) grating products are recommended for areas where physical properties are paramount to design and longevity. Treadwell offers an extensive range of FRP grating products, two of which are highly utilised in the rail industry. There are key differences to take note of. The information below outlines the key differences and the ideal scenarios in which the different types of grating are to be utilised.

## GratEX® Moulded FRP Grating

The perfect solution for areas where excessive amounts of penetrations (i.e. for piping) call for traditional uni-directional spanning products. This greatly increases the costs when using traditional materials, like steel. FRP grating maintains strength and integrity even with multiple penetration cut outs, while keeping costs low.

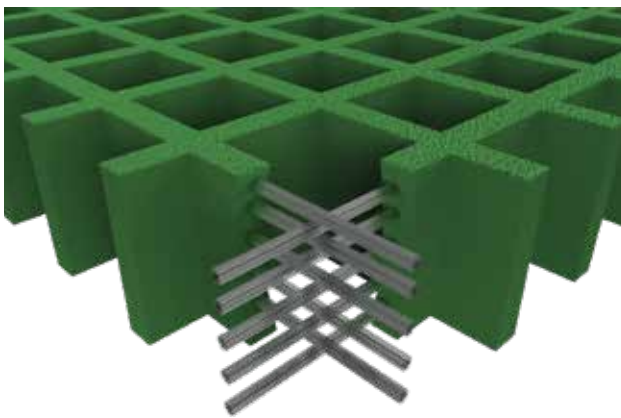

## GridEX® Pultruded FRP Grating

The ultimate choice for areas where extremely high loadings, or larger spans present a challenge. Such applications include wide walkways, or where equipment needs to be installed on top of grating.

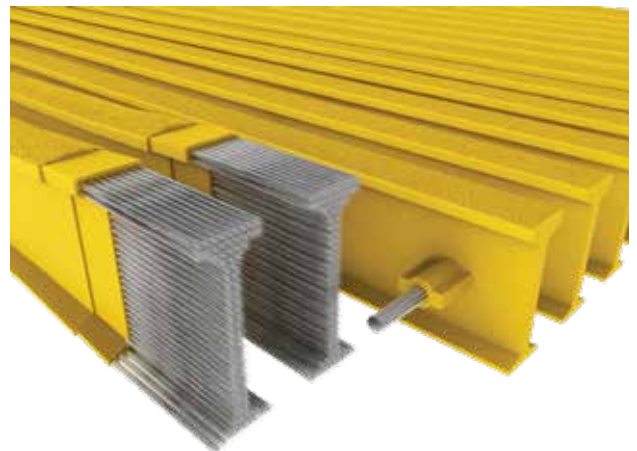

**Please consult our EX-Series® Grating Product Guide for more information.**



**P-Series® Phenolic Grating**

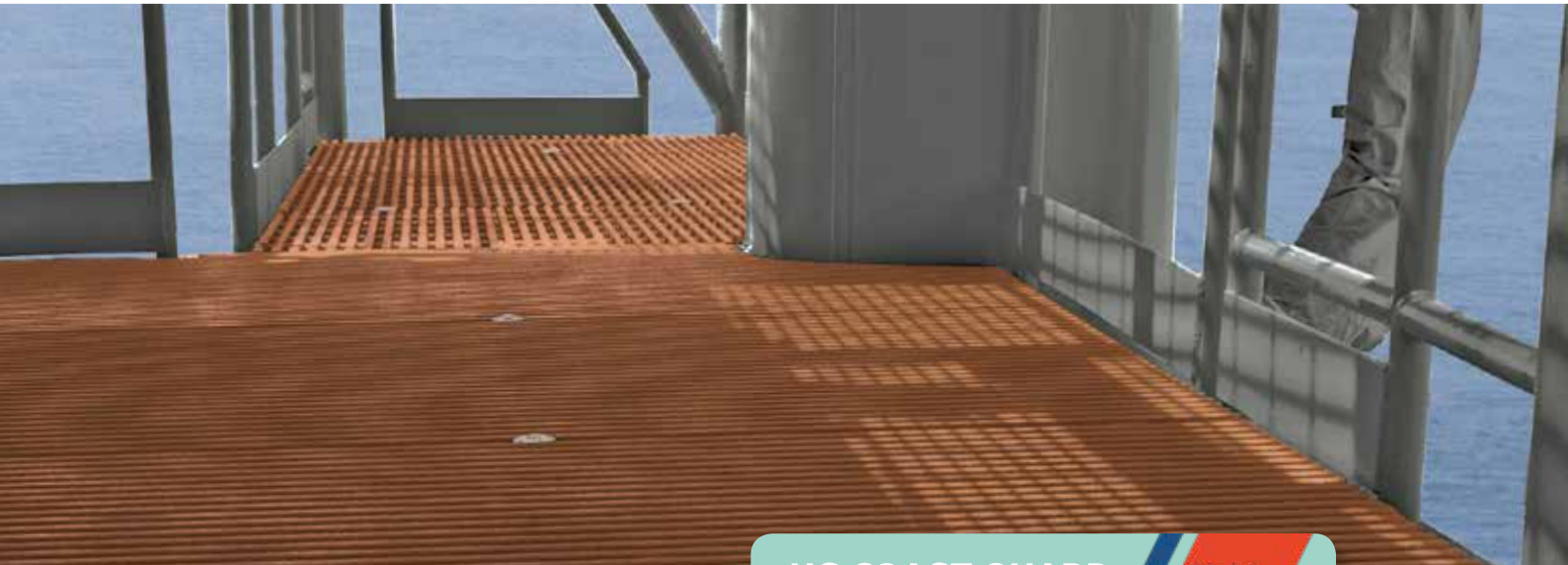

**Treadwell’s P-Series® Phenolic fibreglass or FRP grating is the ultimate choice for applications where fire risk is prevalent and when smoke cannot be allowed to develop.**

Treadwell, through the employment of the most advanced production equipment and the use of the highest quality raw materials, has developed this unique range of leading offshore composite grating products. EX-Series® Phenolic Grating, which boasts US Coast Guard approval, is acceptable for use in areas and applications as outlined in the US Coast Guard Safety Manual Vol III.

**Composite Grating with the Strength of Steel**

EX-Series® Phenolic Grating can span up to 70% more than that of equivalent size standard steel grating. Furthermore, P-Series® will not yield and will return to its original shape if design loads are exceeded.

**Ease of Installation**

EX-Series® Phenolic Grating is only 65% of the weight of steel bar grating and often, can be manually installed with ease.

**Safety Enhancing Anti-Slip Surface**

This system unique to EX-Series® Grating Systems means that load bars are broader than those of metal grating and are far less fatiguing than conventional steel bar grating and not dangerously sharp like serrated surface grating.

**Extreme Fire and Impact Resistance**

EX-Series® Phenolic Grating systems, which is laminated by an outer layer of resin rich Phenolic providing ultimate fire resistance, ensures extreme strength is maintained.

**Typical Applications**

- Jetties, wharfs & marine structures
- Offshore production platforms
- Offshore drilling platforms
- Grating
- Refineries
- Industrial/processing plants
- Shipboard applications
- Public Transport i.e. tunnels

**Standard Panel Sizes**

GratEX®	1222mm x 3662mm
	920 mm x 3055 mm
GridEX®	1524 mm x 6096 mm

Other custom panels sizes are achievable and readily available.

**Installation Methods**

Treadwell offers a range of Installation fixing systems designed for offshore wave zone environments as well as for standard industrial applications – refer to pages 38-41, 50, 68 and 80 for StormChief® system, which has a long-standing history of outstanding performance in the offshore industry.

**Standard Colours**



Antique Brown



Antique Yellow







**GratEX® Clip - Tops**

STANDARD M	MINI MESH M	MINI MESH M (SLOTTED)	C	L
Hole Diameter: 8mm Material type: 316 st/st Threaded hole: N/A	Hole Diameter: 6mm (8mm for GTX-502525M1) Material type: 316 st/st Threaded hole: N/A	Hole Diameter: 6mm Material type: 316 st/st Threaded hole: N/A	Hole Diameter: 6mm Material type: 316 st/st Threaded hole: Yes	Hole Diameter: 6.5mm Material type: 316 st/st Threaded hole: N/A
				

D	E	W	S	O
Hole Diameter: 8.5mm, 7mm Material type: 316 st/st Threaded hole: N/A	Hole Diameter: 8mm Material type: 316 st/st Threaded hole: N/A	Hole Diameter: 8mm Material type: 316 st/st Threaded hole: N/A	Hole Diameter: 8mm Material type: 316 st/st Threaded hole: N/A	Hole Diameter: 8mm Material type: 316 st/st Threaded hole: N/A
				

**Clamp Underside**

J - UNIVERSAL	J - MINI-MESH	H
Hole Diameter: N/A Material type: 316 st/st Threaded hole: N/A	Hole Diameter: N/A Material type: 316 st/st Threaded hole: N/A	Hole Diameter: 8mm Material type: st/st Threaded hole: Yes
		

G	U	V	T
Hole Diameter: 6mm, 8mm Material type: st/st Threaded hole: Yes	Hole Diameter: 8mm Material type: 316 st/st Threaded hole: Yes	Hole Diameter: 8mm Material type: 316 st/st Threaded hole: N/A	Hole Diameter: N/A Material type: 316 st/st Threaded hole: N/A
			

# StormChief

Treadwell developed the StormChief® grating fastening system to provide a solution for fastening down grating products in environments that experience high wave action and subsequently require a fastening system that is designed to withstand wave zone loadings.

Wave action exerts extreme forces on grating, sometimes causing panels to be wrenched off substructures. This damage affects large industrial offshore structures such as oil and gas drilling platforms, dockside walkways or decks, and marine based recreational public infrastructure.

StormChief® Wave Zone Grating Fasteners save organisations large expenses in downtime due to access complications and restrictions and reinstallation costs. Additionally, the systems provide time saving installation methods such as the StormChief® Hybrid System which eliminates the necessity for access to the underside of the substructure.



## StormChief GRIP

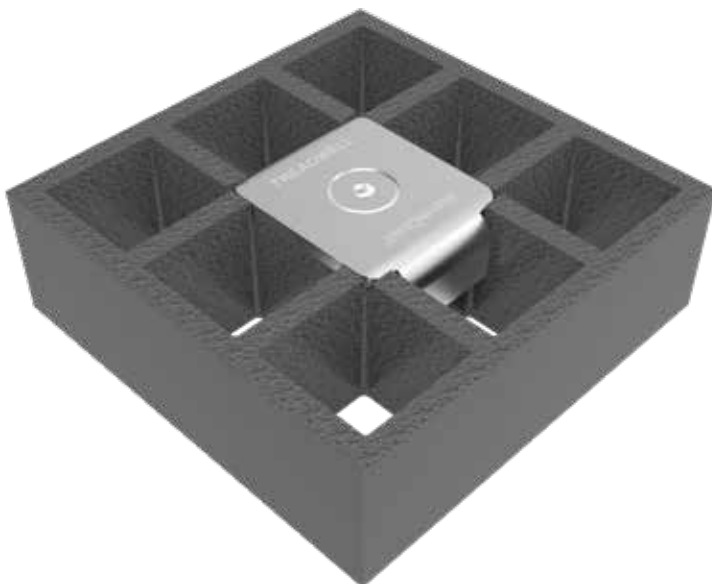

Plan View



Elevation View

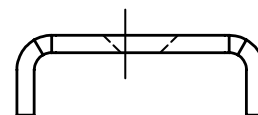

The StormChief® GRIP is ideal for stair treads or grating where the fasteners need to be near the edges, to accommodate load bar considerations. Incredibly secure, this tough fixing clip is made from 316 stainless steel and designed to withstand high wave zone loadings. Sitting flat against the grating, it eliminates risks of trips and snags.



**StormChief DISC®**



Plan View

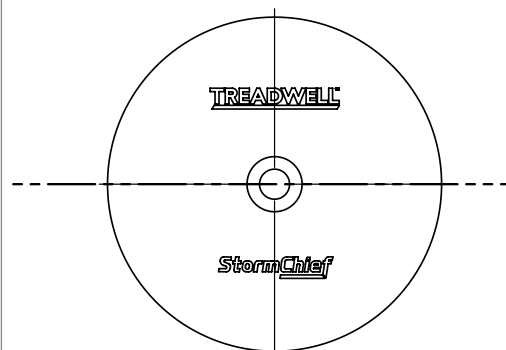

Elevation View

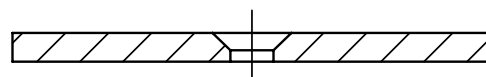

The StormChief DISC® is an extremely robust and secure grating fastening system intended for use in areas that experience high wave zone loadings. The DISC is designed to be used when the width of a walkway or deck area exceeds 1200mm or requires securing in situations where the application of the CLAW system is impractical. The DISC is recessed to ensure safe and secure pathway for all types of traffic accessing the area. This system is compatible with the H-Clip fastener and the StormChief® Hybrid System.

**WARRANTY**

Treadwell offers a bespoke warranty for the StormChief® grating fastening system, provided the following conditions are satisfied:

1. Treadwell prepares the product system and associated attachment hardware drawings and details, and supplies the product system and associated hardware for the product system; and
2. Treadwell is permitted to inspect the installation of the particular product system, or be permitted access to the work for final inspection and approval, and recommend the necessary corrections, if required;
3. In the event of product dissatisfaction, Treadwell be permitted access to the site for the purpose of verifying that the complaint is a direct result of Treadwell's design and/or installation.

For further information, contact your Treadwell representative.

**StormChief® Recess Tool**



**StormChief CLAW®**



Plan View

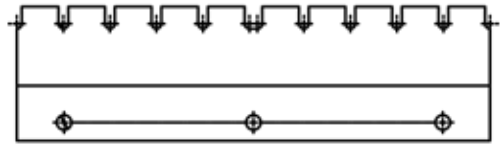

Elevation View

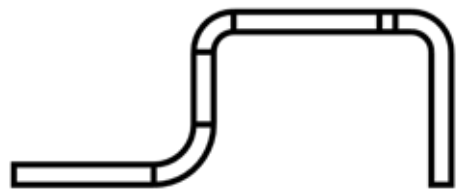

The StormChief CLAW® is a heavy duty 316 Stainless Steel grating fixing bracket that is designed to meet and exceed specifications for wave zone loadings. With integrated fingers that protrude into the grating aperture, the StormChief CLAW® provides secure fastening in even the harshest of coastal conditions. Used exclusively in conjunction with the StormChief® Hybrid System, it ensures simple, strong and rapid installation.

**StormChief CLAMP®**

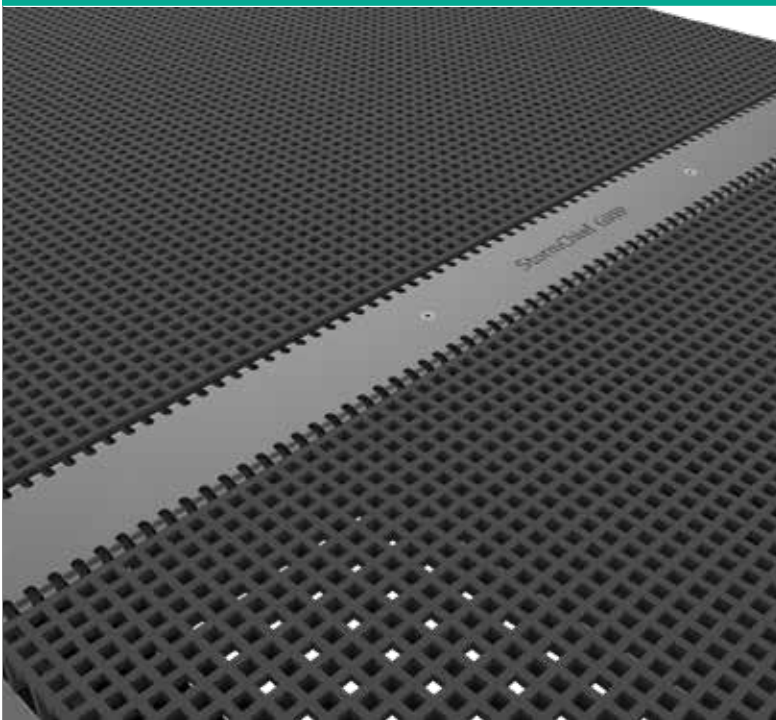

Plan View



Elevation View



The StormChief CLAMP® is a rugged stainless steel clamping bracket that is designed to meet and exceed the requirements of extreme wave zone loadings. The StormChief CLAMP® is a unique clamping system designed by Treadwell to seamlessly join two sheets of grating along one edge. This clip is easily recessed into the grating to ensure minimal trip hazard, making it ideal for public access areas that are subject to harsh coastal conditions.



## Case Study – Subsea7



PROJECT INFORMATION	
Project Category:	Oil & Gas Facility
Scope of Work:	Supply FRP grating
Treadwell Products:	EX-Series® GridEX® FRP grating

Western Australia – Subsea7 has been in operation for over five decades, working in water depths across all energy hubs. They are a global leader in delivering projects and services to the offshore oil and gas industry. They offer a full range of early concept, engineering services, procurement, construction and installation.

Treadwell was engaged to supply the grating for one of these platforms.



Images used are for illustration purposes only.

### Treadwell's Solution:

- 1

GridEX® FRP pultruded grating provides fantastic uni-directional strength. This is the ultimate choice for areas where extremely high loadings, or larger spans need to be addressed.

---

- 2

Constructed with a very hard-wearing surface with a great coefficient of friction (NATA laboratory test report available) provides incredible anti-slip resistance.

---

- 3

Unlike serrated steel grating, the anti-slip surface does not impact on load carrying capacity.

---

- 4

GridEX® boasts high ratings of impact and chemical resistance.

## Case Study – Darwin LNG



PROJECT INFORMATION	
Project Category:	Oil & Gas Facility
Scope of Work:	Supply FRP grating
Treadwell Products:	EX-Series® GridEX® FRP grating – U.S. Coast Guard Level 2.

Northern Territory, Australia –Construction of Darwin LNG began in 2003, with the plant commissioned in 2006. This was the first LNG project in the Northern Territory and the second in Australia. This facility includes a central production and processing complex with a Floating Production Storage and Offloading vessel for condensate and LPG products and an unmanned wellhead platform.

Treadwell was engaged to supply the grating for part of this plant.



Images used are for illustration purposes only.

### Treadwell's Solution:

- 1

Treadwell's GridEX® FRP grating meets compliance standards as per USCG Level 2 – surface flammability and structural fire integrity.

---

- 2

Resin systems used include fire retardant additives, making it ideal for this application.

---

- 3

FRP has naturally low thermal and electrical conductivity.



## Case Study – INPEX Darwin



PROJECT INFORMATION	
Project Category:	Oil & Gas Facility
Scope of Work:	Supply FRP grating
Treadwell Products:	EX-Series® GridEX® FRP grating – U.S. Coast Guard Level 2.

Northern Territory, Australia – INPEX has a long and successful business relationship with Australia that began in 1986. Globally, INPEX is a major player in the production of clean, efficient and reliable natural gas for the Asia-Oceanic region. INPEX has an interest in the Bayu-Udan offshore gas and condensate field in the Timor Sea, and a corresponding interest in the Darwin LNG facility.

Treadwell was engaged to supply the grating for part of this facility.



Images used are for illustration purposes only.

### Treadwell's Solution:

- 1

Treadwell's GridEX® FRP grating is approximately 35% lighter than aluminium and 75% the weight of steel. This makes the handling and installing processes easier.

---

- 2

GridEX® grating can be easily cut onsite using simple hand tools. Unlike metal grating, no 'hot-work' tools like grinders or torches are required.

---

- 3

GridEX® grating is designed to handle high weight loading over long spans.

## What is RailEX® ROUND Tubular Handrail?

Treadwell's RailEX® ROUND Tubular Handrail is an industrial rated composite handrail system which combines strength, durability and versatility meaning the system is ideal for use in numerous applications in a vast range of industries. Treadwell can supply RailEX® as either components or as fabricated handrail panels ready for installation.

### Smart Transposable Designs

Unlike traditionally welded alternatives, Treadwell FRP handrail system dispenses the need for drafting, engineering and onsite fabrication while minimising installation costs. Treadwell's safety handrail systems can be adapted or extended with additional components, or cut to size onsite. Pre-engineered kits are supplied as a series of components with simple assembly instructions. With our clients in mind, Treadwell aims to minimise the cost of maintenance and repairs, and damaged components easily with readily available parts and stock.

### Simple Zero Weld Assembly

As an added benefit, fibreglass handrail kits are assembled using a simple, zero weld construction method; reducing the chances for corrosion activation. Treadwell's RailEX® designs and fittings effectively eliminate the need for specialist trades, hot works permits, fire spotters and welding protection to finished surfaces. Our selection of FRP increases safety conditions for installers by eliminating toxic fumes, welding in wet areas and fire risk hazards.

Developed by Treadwell with the input of designers, and plan operators, this system offers you all benefits of traditional guardrail systems without the inherent problems - corrosion, welding and hot works permits for onsite modifications. This unique system is a first to be tested and conform with Australian Standards AS 1657. RailEX® is the **'Fit & Forget'** handrail system.



This product conforms to AS1657



## RailEX® Features and Benefits vs. Traditional Alternatives

	RailEX®	Stainless Steel	Galvanised Steel	Aluminium	Timber
Chemical Resistance	•••••	•••••	•	•••	•••••
Strength	•••••	•••••	•••••	•••••	••
Lightweight	•••••	•	•	•••••	••
Electrical Resistance	•••••	•	•	•••••	•••••

### Materials of Construction

RailEX® FRP handrail is constructed from fibreglass rovings combined with a blend of thermosetting resin systems. All of the resins used in the production of EX-Series® products contain UV inhibitors and fire retardant additives.





# RailEX® ROUND Overview

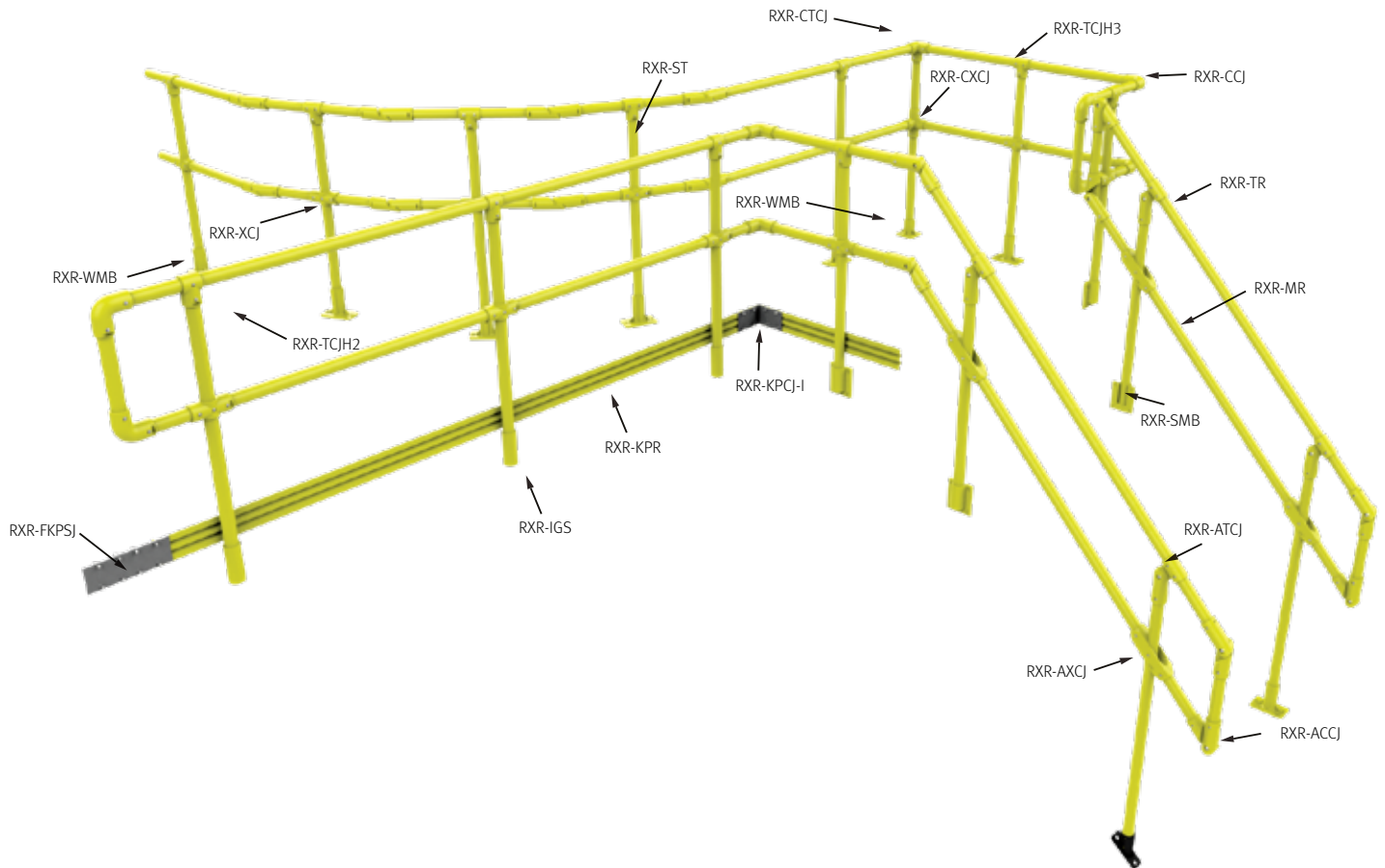

**Please consult our RailEX® Handrail Installation and Product Guides for more information.**





## RailEX® ROUND Stanchion Kits & Handrail Parts

Treadwell has created options of RailEX® handrail stanchion kits. This ensures that all the required parts are included, making for easy planning and installation. Please note that the list below is just a selection of our most popular handrail assemblies. For a more comprehensive selection, please consult our RailEX® Product Guide .

RXR-SN-VY-K	RXR-SS-VY-K	RXR-AA-VY-K	RXR-AS-VY-K
<p>RailEX® ROUND Stanchion Sales Kit, Standard Stanchion with Narrow Mounting Bracket, V-Series® Safety Yellow, including Stainless Steel Fasteners.</p> <p>NOTE: Assembly excludes fasteners to connect to structure.</p>	<p>RailEX® ROUND Stanchion Sales Kit, Standard Stanchion with Side Mounting Bracket, V-Series® Safety Yellow, including Stainless Steel Fasteners.</p> <p>NOTE: Assembly excludes fasteners to connect to structure.</p>	<p>RailEX® ROUND Stanchion Sales Kit, Adjustable Stanchion with Angled Round Top Mount Bracket, V-Series® Safety Yellow, including Stainless Steel Fasteners.</p> <p>NOTE: Assembly excludes fasteners to connect to structure.</p>	<p>RailEX® ROUND Stanchion Sales Kit, Adjustable Stanchion with Side Mounting Bracket, V-Series® Safety Yellow, including Stainless Steel Fasteners.</p> <p>NOTE: Assembly excludes fasteners to connect to structure.</p>
<p>RXR-CC Standard ROUND Fibreglass 90° Corner Connection Joint</p>	<p>RXR-XCJ Standard ROUND Fibreglass Cross Connection Joint</p>	<p>RXR-TCJH2 Standard ROUND Vertical Fibreglass Connection Joint</p>	
<p>RXR-TCJH3 Standard ROUND Horizontal Fibreglass Tee Connection Joint (three holes)</p>	<p>RXR-TRJ Standard ROUND Fibreglass Top Rail Joiner</p>	<p>RXR-ACCJ Adjustable ROUND Fibreglass Corner Joint</p>	
<p>RXR-AXCJ Adjustable ROUND Fibreglass Cross Connection Joint</p>	<p>RXR-ATCJ Adjustable ROUND Fibreglass Tee Connection Joint</p>	<p>Standard Stainless Steel Driver Kit M6 Type with Trilobular Head</p>	
<p>RXR-SMB Standard ROUND Fibreglass Side Mounting Bracket</p>	<p>RXR-NMB Standard ROUND Fibreglass Narrow Mounting Bracket</p>	<p>Standard Stainless Steel Fastener Kit M6 with Trilobular Head (stock item)</p>	<p>Standard Stainless Steel Fastener Kit M10 (stock item)</p>

## Case Study – PTTEP Australasia



PROJECT INFORMATION	
Project Category:	Oil & Gas Facility
Scope of Work:	Supply FRP handrails
Treadwell Products:	EX-Series® RailEX® ROUND FRP Handrails

Western Australia – A wholly owned subsidiary of the Thai national petroleum exploration and production company, PTTEP, operates more than 40 projects globally. In Australia, PTTEP maintains a 100% interest in the highly prospective Cash Maple gas and condensate field, as well as a number of other exploration permits and retention leases in Australian Commonwealth waters.

Treadwell was engaged to supply the handrails for this facility.



Images used are for illustration purposes only.

### Treadwell's Solution:

- 1

Treadwell's uniquely designed RailEX® FRP handrails is a zero weld method of assembling the system. This greatly lowers the risk of corrosion.

---

- 2

Easily assembled and installed, this excludes the need to seek specialist trades, fire spotters, hot works permits and welding protection.

---

- 3

Durable, with a long design life, the costs of maintenance and repairs are minimised.



## What is EX-Series® Industrial Composite Solutions?

A designed composite structural and access solution featuring a combination of our FRP products.

These access structures are easily installed in elevated, remote, indoor or outdoor locations, and possess corrosion resistant and low electrical conductivity properties.



### FIXED STAIRCASES

An FRP solution featuring a combination of ArchitEX™ structural profiles, EX-Series® grating and stair treads, and RailEX® handrails. Built to withstand corrosive indoor and outdoor environments.



### FIXED ACCESS PLATFORMS

These can be customised to the span required for its purpose. Being naturally non-conductive, FRP is a cost-effective and long-lasting solution for corrosive environments.



### FIXED STEPOVERS

All GratEX® and MoultrEX® premium and standard Stair Tread options are moulded with the solid leading-edge nosing as joint single stage component. This increases the rigor and sturdiness of the entire leading edge ensuring dependable performance in high traffic situations. All the treads with abrasive leading-edge nosings are manufactured to conform to AS 1657 – 2018.



### PLATFORMS

Treadwell's TreadSLAB® FRP panels are constructed with an anti-slip surface and corrosion resistant properties. This maintains optimal user safety. Panels can also be customised according to load requirements.



## Case Study – ExxonMobil Bass Strait



PROJECT INFORMATION	
Project Category:	Oil & Gas Facility
Scope of Work:	Supply FRP products
Treadwell Products:	EX-Series® RailEX® ROUND FRP Handrail, GratEX® FRP Square Mesh Grating, SAFE-SERIES™ StairSAFE™ FRP stair nosing

Bass Strait, Victoria – With over 20 offshore platforms and installations in the Bass Strait, these platforms are in operation 24 hours a day. These installations recover crude oil, condensate and natural gas which, with associated water, are trapped in subsea sandstone reservoirs located between 1200 and 2500 metres below sea level. When the fluids reach the platform, they are separated into oil, gas and water. A network of underwater pipelines bring the oil and gas onshore from the platforms.

Treadwell was engaged to supply a range of FRP products for one of these platforms.

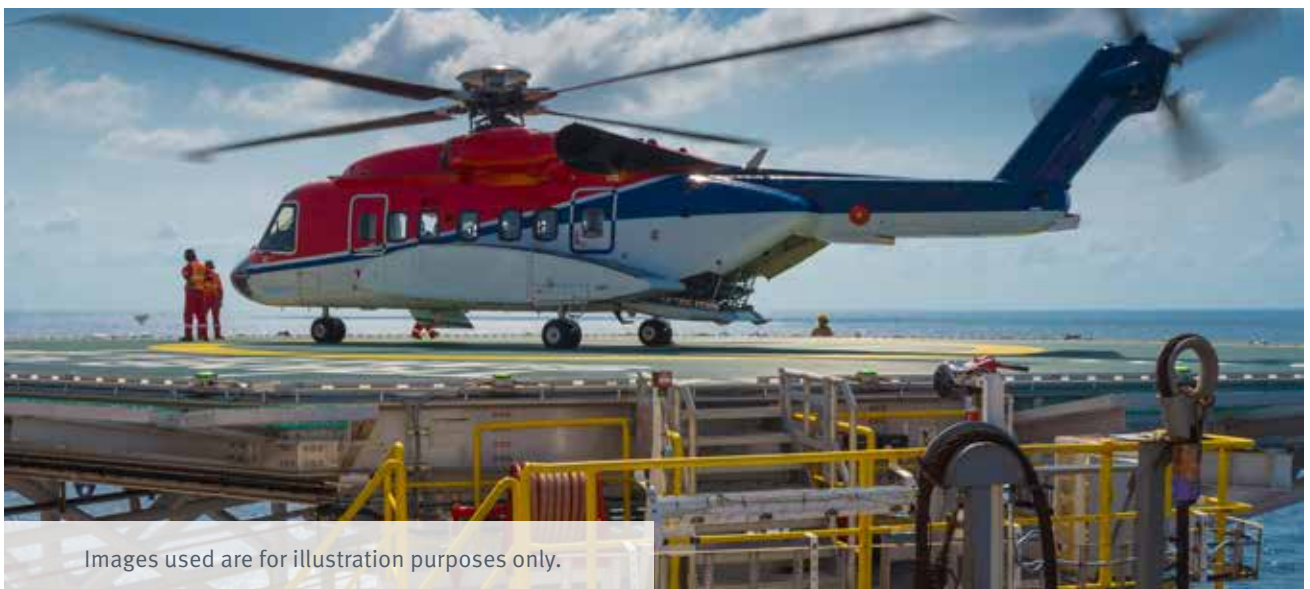

Images used are for illustration purposes only.

### Treadwell's Solution:

- 1

The resin systems used in Treadwell's FRP products are customised to suit its application. This includes corrosion resistant properties, with a fire-retardant formula.

---

- 2

The unique finishing of the RailEX® handrails minimise the risks of delamination.

---

- 3

The aperture of the GratEX® FRP Square Mesh allows for maximum fall through of debris, minimising the accumulation of stagnant debris.

---

- 4

StairSAFE® FRP stair nosing is designed to endure severe conditions and environments given its robust construction. The grit surfaces are permeated into the substrate, for a durable and long-lasting anti-slip surface.

---

- 5

FRP is naturally non-conductive, making it ideal for this application.

## Case Study – Chemical Manufacturing Plant



PROJECT INFORMATION	
Project Category:	Chemical Manufacturing Plant
Scope of Work:	Supply EX-Series® FRP Solution
Treadwell Products:	EX-Series® GratEX® FRP Square Mesh Grating EX-Series® RailEX® ROUND Handrails ArchitEX™ secondary framing & joists

A diversified chemical manufacturer, this proudly Australian owned company has multiple plants in Australia and Malaysia. Established in the early 1970s, they have come a long way and have expanded their portfolio over the years. In addition to chemical manufacturing, their capabilities include related bulk chemical and fuels storage and handling, as well as terminal infrastructure management. One of their major business commitments is the focus on operational safety.

As part of the extension of their plant in Brisbane, Treadwell was engaged to supply the FRP grating and handrails.



### Treadwell's Solution:

- 1

Treadwell's EX-Series® GratEX® FRP grating and RailEX® ROUND handrails ensure durability with built-in corrosion resistant properties.

---

- 2

Treadwell's ArchitEX™ secondary framing and joists are non-conductive and non-corrosive, making it ideal for this application.

---

- 3

With a ready stock of GratEX® grating panels and RailEX® parts, repairs and replacements, if needed, are easily managed.

---

- 4

GratEX® stair treads moulded with a solid leading-edge stair nosing were used. This increases the rigor and sturdiness of the entire leading edge, ensuring dependable performance in high traffic situations.

---

- 5

FRP is simply fabricated and modified on site. This means there is no need for any hot works permit.

---

- 6

Being lightweight and easy to install, FRP is very manageable during construction.

## EXduro™ Cable Ladders

For environments where corrosive elements play a crucial part in a material, Treadwell has developed its FRP cable ladders as a strong support solution as the alternative to metal cable ladders. Being lightweight, it allows for easier installation or onsite fabrication as well as giving the cable ladder a high strength to weight ratio.





EXduro™ fibreglass cable ladders has several other benefits that may be useful. It is both a UV resistant and fire retardant system. Transparent to RF frequencies and electrically non-conductive are other positives it can bring to any design.

EXduro™ fibreglass cable ladders are also a cost competitive, performance proven alternative to metal systems for that corrosive/chemical environment to run your electrical cable and instrumentation pipe work. With minimal to no ongoing maintenance, Treadwell's system is supplied with both FRP and stainless steel fasteners to suit your application.

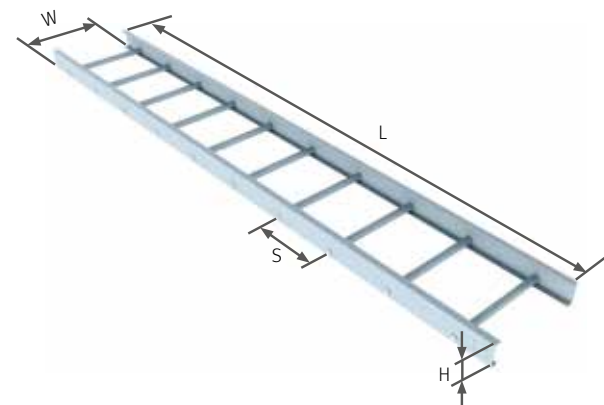
F-EXD-CL-C(H)(W)-(R)(S)-(RS)(C)-(L)						
Side Rail Height (H)	Width (W)	Rung Type (RT)	Rung Spacing (S)	Resin (RS)	Colour (C)	Length (L)
50mm (050)	150mm (150)	Standard Rung (S)	150mm (150)	Standard Polyester (SI)	Light Grey (LG)	3m (1) N
75mm (075)	300mm (300)	Marine Rung (M)	250mm (250)	Standard Vinylester (SV)	Custom Colour (CC)	6m (2) C
100mm (100)	450mm (450)		300mm (300)	Conductive Polyester (CI)		
150mm (150)	600mm (600)		450mm (450)	Conductive Vinylester (CV)		
200mm (200)	750mm(750)		Halogen free Polyester (HI)			
	900mm (900)		Halogen free Vinylester (HV)			
				Halogen free Low Smoke Plus (HF)		

### EXduro™ Cable Ladder



Straight splice plate	90 Vertical splice plate
	
Adjustable vertical splice plate	Adjustable Horizontal splice plate
	

### Cable Ladder Splice Plates

Our splice plates are available in both horizontal and vertical degree sections. We also offer the accompanying accessories separately. We construct both flat and peaked covers. These plates are non-conductive and do not react on electric and magnetic fields.



## Case Study – The Gorgon Project, Chevron



PROJECT INFORMATION	
Project Category:	Oil & Gas Facility
Scope of Work:	Supply FRP cable management
Treadwell Products:	EXduro™ FRP Cable Ladders

Barrow Island, Western Australia – Gorgon is one of the world’s largest liquified natural gas (LNG) projects and the largest single resource project in Australia’s history. Gorgon comprises a three-train, 15.6 million tonnes per annum LNG facility and a domestic gas plant with the capacity to supply 300 terajoules of gas per day to Western Australia.

With a predicted project lifespan of more than 40 years, the development of Gorgon is a legacy in reliable energy supply, environmental management, innovative technology and expertise.

Treadwell was engaged to supply the cable ladders for this facility.



Images used are for illustration purposes only.

### Treadwell's Solution:

- 1

Constructed from premium resin systems, EXduro™ FRP Cable Ladders are corrosion resistant, with fire retardant properties, as well as UV inhibitors, making it ideal for this outdoor and corrosive environment.

---

- 2

EXduro™ Cable Ladders are compliant up to NEMA 20C. This means these are built for long spans, eliminating the need for costly supports, while meeting compliance codes.

---

- 3

Lightweight and easy to install, EXduro™ is cheap to transport, and doesn't require heavy machinery for installation.

---

- 4

Given the nature of FRP, any system utilising it is virtually maintenance free, keeping maintenance costs to a minimum.

## What is EX-Series® LadderEX® FRP Ladders?

**LadderEX® is the superior alternative to metallic ladders and cage systems, providing excellent corrosion resistance and electrical transparency. Even in complete immersion applications, Treadwell's fibreglass ladders have outlasted aluminium and steel, and required little or no maintenance.**

Our products in this range are made from superior fibreglass which offers unparalleled advantages, leaving behind alternatives that are metal or steel based. Our ladders and ladder cage systems are produced using a premium grade polyester resin system with flame retardant and ultraviolet (UV) inhibitor additives. A vinyl ester resin system is available upon request for additional corrosion resistance. Standard side rails and cages are in safety yellow. The rungs are a pultruded fibreglass polyester tube with a fluted, non-skid surface.

LadderEX® fibreglass ladder systems are fabricated and designed with FRP according to AS 1657-2018. The pultruded parts are produced with a fire retardant polyester resin which meets the ASTM E-84 test for flame spread of 25 or less and contains a UV inhibitor. The colour is in standard OSHA safety yellow though colour matching can be provided.

Ladders are shop assembled and may be pre-drilled and prepared for field attachment with standoff clips and/ or base brackets systems.

The LadderEX® product range can easily be integrated into any existing platform or structure. It can come in a variety of configurations to suit any purpose as well.



### LadderEX® Standard Ladder with ROUND Grab Stiles

LDX-RG

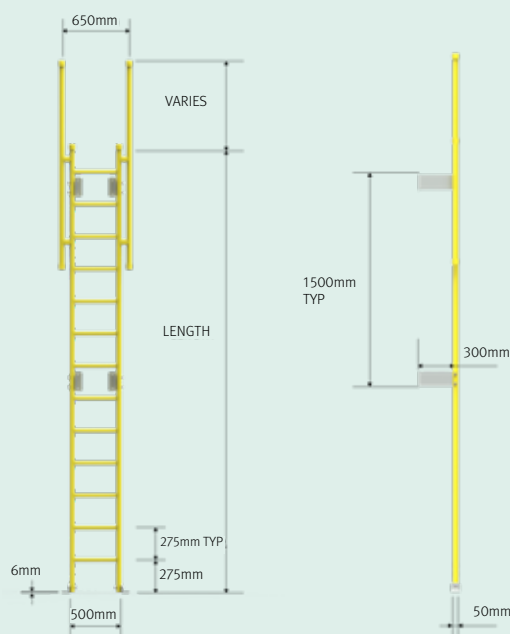

**Brief:**

In instances where there is a requirement for extra security above 1.5m, Treadwell can supply standard access ladders without returns with a round grab stile.



**Please consult our LadderEX® Product Guide for more information.**

LadderEX® Heavy Duty Wall Mounted SQUARE Ladder
LDX-SL

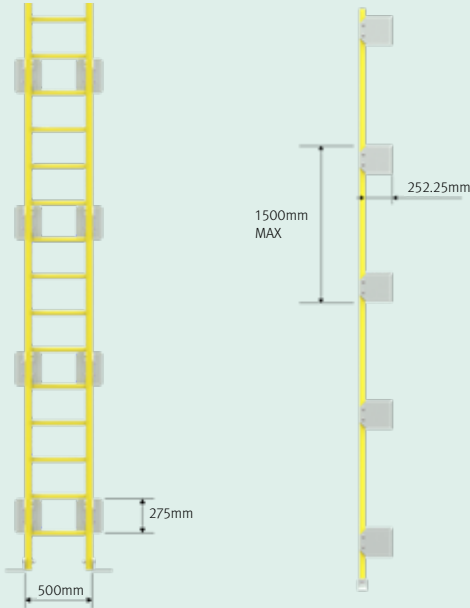
**Brief:**  
 For industrial and other heavy duty purposes, Treadwell supplies a more durable and robust heavy duty wall mount and floor mounts (if required) for that added safety factor.

## **R**ETRACT-A-STILES

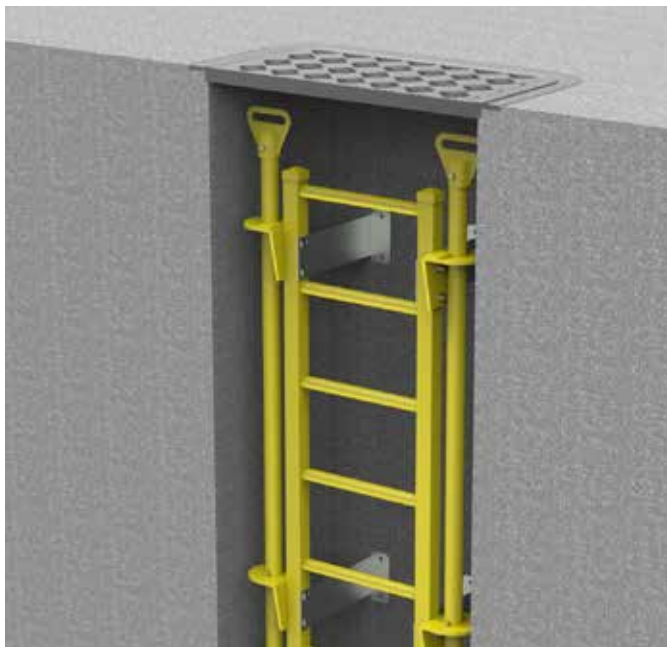

### What are LadderEX® Retract-A-Stiles?

LadderEX® Retract-A-Stiles offer convenience, flexibility, and enhanced safety, especially in confined spaces. Constructed from corrosion-resistant FRP, they require minimal maintenance. Easy to install, they ensure safety at heights with ergonomically designed handles for superior grip and robust fixing brackets for strength and versatility.

LadderEX® components are modular, allowing numerous ladder and access configurations to meet specific site requirements. We can easily integrate your needs into any Retract-A-Stile design.

To comply with AS 1657 standards, ladders must be at least 1700mm long, with stiles extending at least 1000mm above the top landing. The gap between ground level and the first rung should be no less than 90% of the spacing between other rungs.

While Treadwell strives to ensure compliance with AS 1657, bespoke solutions may sometimes result in non-compliant products. In these cases, client approval to proceed is considered consent to supply non-compliant goods or services.



**SAFE-SERIES™**  
Industrial Anti-Slip Solutions

**Anti-Slip Safety Solutions**

SAFE-SERIES™ is Treadwell's selection of pre-manufactured and ready made for installation anti-slip products for harsh environments.

Fabricated from FRP composites, anti-slip decks and rung covers are easy to install over existing stairs to create the toughest and most dependable anti-slip surface available.

Proven in many applications, the series is available in various styles and colours to suit any environment.

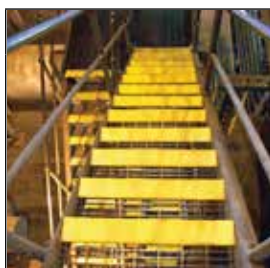

**StairSAFE™**

Long wearing, anti-corrosive, non-slip nosing designed to re-profile the leading edge of any step are the characteristics of StairSAFE™.



**CableSAFE™**

CableSAFE™ creates a safe walkway over exposed pipes, cables, wires and conduit. With a durable anti-slip surface, CableSAFE™ provides a safety bridge for foot traffic over these areas, avoiding slips, trips and falls.



**RungSAFE™**

The abrasive grit surface eliminates the very high possibility of slips from access ladders, avoiding serious ramifications. The surface, while ideal for the negation of slip issues, has been developed so as not to damage bare skin.



**DeckSAFE™**

DeckSAFE™ is the ultimate solution for slippery ramps, decks, catwalks and landings. Designed to reduce the risk of slips, trips and falls in areas where oil, water and other forms of liquids are present, DeckSAFE™ greatly reduces risks.

**EASY INSTALLATION**

Heavy duty industrial fixings for all applications. Surface for rungs normally applied by using a polyurethane adhesive glue system.



**OPTIONAL DEPTH AND LENGTH**

Available in four standard depths, 50mm, 75mm, 100mm and 300mm. Custom depths are also available up to 300mm. Available in any length up to 3,250mm.

**SAFETY**

Heavy duty grit layer provides an ideal anti-slip surface; likewise, safety yellow offers enhanced visibility.

**CHEMICAL RESISTANT**

Designed to handle most chemicals. Please refer to our Chemical Resistance Guide, found in our SAFE-SERIES™ Product Guide.

**ZERO TRIP RISK**

Smooth bullnose, sloped on an 85° inclined plane ensures no trip risk is posed.

**ROBUST CONSTRUCTION**

Specially formulated resin systems and metallic available on request.

**ArchitEX™**  
Structural Profiles & Structures

**Composite Structural FRP**

The ArchitEX™ range of products comprises of a variety of structural profiles that are manufactured from Fibreglass Reinforced Plastic (FRP). It is through continual research and development that this wide range of fibreglass sections, beams, and profiles are fabricated consistently to ensure satisfactory results even in challenging structural conditions.

The FRP beams, columns and associated sections are produced from high quality FRP material, which makes structures strong as well as rewarding. Durable construction FRP such as fibreglass sections and beams enhances the strength of the entire framework as well as infrastructure. Both fibreglass beams and sections are specifically designed to endure all sorts of environmental inconsistencies.



**Scope of Shapes**

Easy integration to various parts due to the capability to essentially shape any item with a constant cross section which can be pultruded.

**Composite Design Engineering**

A standard shape customised into a pultrusion by modifying the resin or reinforcement to achieve a particular customer need.

**Optimising Resins**

Standard resins can be modified or special resins can be used to maximise performance of the pultrusion in challenging environments, such as those found in high temperature or extremely corrosive areas. Typical resins include polyesters, vinylesters, PVC, epoxies, phenolics, urethanes and blends.

**Choice of Reinforcements**

The type, form, placement and quantity of reinforcements can be customised to optimise economy, develop ascribed strength and create or enhance other physical characteristics of a pultruded part. Typical reinforcements used include glass or carbon fibres in multifilament strands, mat (long fibres held together with a resinous binder) or stitched fabrics.

**Core Materials Options**

Treadwell provides a range of core material options with comprehensive experience in pultruding over various materials including foam, balsa, polyethylene and aluminium.

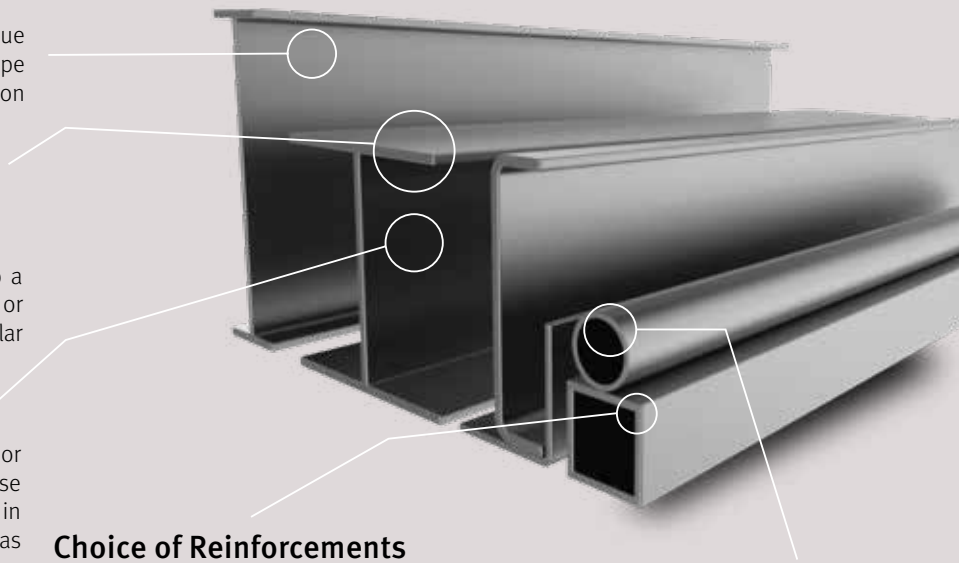











**Structural Design & Analysis**

Our experienced team of engineers and designers can help conceptualise your design and maximise all FRP structural components to offer the most cost effective and simplest solution.



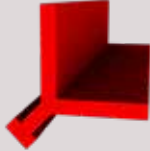

## ArchitEX™ FRP Profiles

ArchitEX™ Range		
C Channel	I-Beam	WF-Beam
		
Double Web Beam	Unequal Leg Angle	Equal Leg Angle
		
Square Hollow Section	Rectangular Hollow Section	Circular Hollow Section
		
Circular Round Bar	Solid Bars	Embedment Angle
		

**Please consult our ArchitEX™ Structural Product Guide for more information.**





## TreadSLAB® Panel Types Available

### TreadSLAB®

TreadSLAB® is an immensely versatile profile which combines lightweight and inherent strength to provide a durable product with a variety of surface textures and a customisable range of colours. Through the selection of the appropriate resin system, the user can create components that will meet the most demanding of specifications.

Pultruded through a die, TreadSLAB® outperforms with an impressive strength to weight ratio to produce a composite flooring structure that is strong, durable, corrosion resistant and boasts low maintenance on an anti-slip surface.

#### Benefits

- High strength
- Light weight
- Dimensional stability
- Corrosion, chemical, electrical resistance
- Low tooling/installation cost
- Long life
- Favourable performance/lifecycle cost basis versus traditional materials

TreadSLAB® easily outperforms traditional materials in terms of performance/ lifecycle costs.

#### Part: TreadSLAB® Medium Duty Panel

Part Number: ARX-SL040

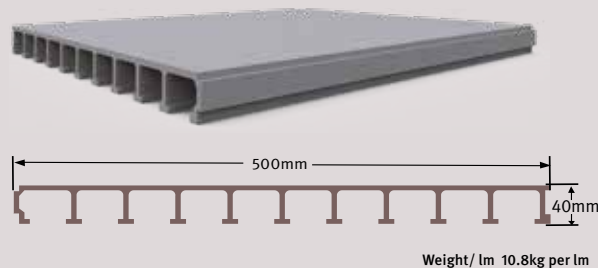

#### Part: TreadSLAB® Heavy Duty Panel

Part Number: ARX-SL100

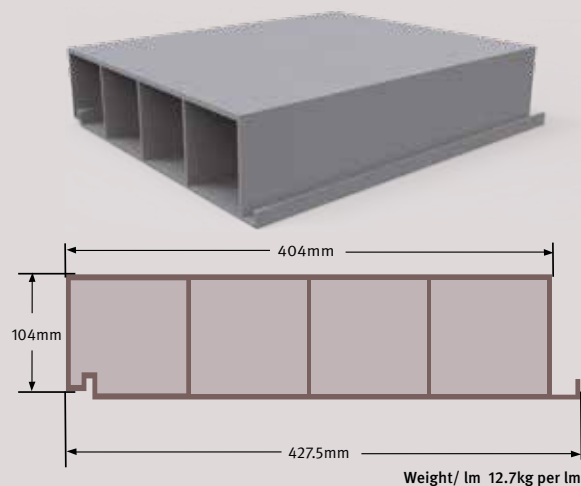

# Our Partners





Strathalbyn, South Australia - Factory & Warehouse





### Material Availability

We have established extensive stockholdings in Australia, ready to be fabricated or shipped according to your project requirements. With offices and warehouses located throughout Australia, shipment to site can be quickly arranged.

Our in-house design and engineering teams have exceptional CAD capabilities. Our factory features top of the range automated CNC equipment allowing project requirements to be quickly fulfilled.

Strathalbyn, South Australia - Factory & Warehouse



## Australia

### SOUTH AUSTRALIA

▶ **ADELAIDE (HEAD OFFICE & WAREHOUSE)**

58 DEEDS ROAD  
NORTH PLYMTON, SA 5037

▶ **STRATHALBYN (FACTORY & WAREHOUSE)**

22 DUNREATH ROAD  
STRATHALBYN, SA 5255

### VICTORIA

▶ **MELBOURNE (BRANCH OFFICE & WAREHOUSE)**

37 MACAULAY STREET  
WILLIAMSTOWN, VIC 3016

### NEW SOUTH WALES

▶ **SYDNEY (SERVICED OFFICE)**

SUITE 9, 35-36  
EAST ESPLANADE MANLY, NSW 2095

▶ **WAGGA (BRANCH OFFICE & WAREHOUSE)**

13 CHESHIRE ST,  
WAGGA WAGGA, NSW 2650

### QUEENSLAND

▶ **BRISBANE (SERVICED OFFICE)**

OFFICE 32, 59 ALBANY CREEK ROAD  
ASPLEY, QLD 4034

### WESTERN AUSTRALIA

▶ **PERTH (BRANCH OFFICE & WAREHOUSE)**

UNIT 2, 4 ELMSFIELD ROAD  
MIDVALE, WA 6056

### TASMANIA

▶ **BURNIE (DISTRIBUTION CENTRE)**

28-30 BRICKPORT ROAD  
COOEE, TAS 7320

## New Zealand

### NORTH ISLAND

▶ **PALMERSTON NORTH (OFFICE & WAREHOUSE)**

36 RATANUI STREET AORANGI,  
FEIDLING 4775



**TREADWELL™**

COMPLETE "Fit & Forget" SOLUTIONS