

# TREADWELL™

COMPLETE “Fit & Forget” SOLUTIONS

## Sector Guide

# MINING & MINERAL PROCESSING



ENGINEERING THE FUTURE IN COMPOSITES

[www.treadwellgroup.global](http://www.treadwellgroup.global)

# Let Treadwell Help You Release the Power of Engineered Composites on Your Next Project

## Corrosion Resistant



- Manufactured from premium isophthalic and vinyl ester resin systems.

## Cost Savings

- Longer service life, less maintenance, and life cost savings as compared to other materials.
- Allows better and viable components into the associated framework.

## High Strength

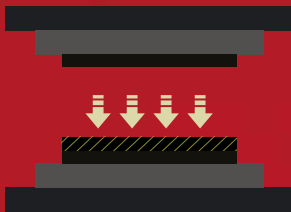

- Manufactured by automated pultrusion process.
- Utilises high glass-fibre content and results in unparalleled product consistency.
- Compression moulding and vacuum moulding processes are used.

## Turnkey Solutions



- Pre-fabricated to eliminate field fabrication and make installation quick and easy.
- Solutions include all necessary accessories.

## Customised System

- Our experienced technical team customises designs to meet project specific load requirements.

## Durability



- Highly durable.
- Greater resistance to breaks and twists which ensure better longevity.
- Reduce the harmful effects of added tension on the surface and relieving the framework.

## UV Protection



- Exterior coatings and stabilisers provide UV protection and ensure long service life.

## Low Profile

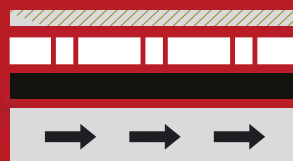

- Aesthetically pleasing flat covers.
- Eliminate confined-entry issues.
- Provide protection for equipment located on top of the cover instead of below.

## Light Weight



- Strength-to-weight properties of FRP reduce loads on tank walls and floors.
- Ease cover removability and installation.
- Can be transported anywhere easily and installed seamlessly.

## No Dissimilar Metals



- Eliminates issues surrounding dissimilar metals

# Contents

04	What You Get When You Work with Treadwell
05	Bespoke & Specialised Projects - Our Process Explained
06	Why Choose Treadwell?
08	EX-Series® FRP Grating
10	Grating Clips
11	Case Study – Lithium Processing Plant
12	Case Study – Copper Concentrate Processing Plant
13	Case Study – Zinc Processing Plant
14	Case Study – Salt Wash Plant Screen Guards
15	Case Study – Metals Mining Facility
16	Case Study – Gold Mine Facility
18	RailEX® ROUND Tubular Handrail
19	RailEX® ROUND Overview
20	RailEX® ROUND Stanchion Kits & Handrail Parts
21	Case Study – Port Latta Iron Export Site
22	Case Study – Nickel Processing Plant
23	Case Study – Tailings Pump Station
24	EX-Series® Industrial Composite Solutions
25	Case Study – Chemical Manufacturing Plant
26	Case Study – FRP Pump Support & Access Structure
27	Case Study – Mineral Processing Plant Cooling Tower
28	Case Study – Salt / Bitterns Discharge Winch Tower & Bridge
30	EXduro™ Cable Ladders
31	Case Study – Zinc Refinery Plant
32	Case Study – Solar Salt Mine Processing Plant
34	EX-Series® LadderEX® FRP Ladders
35	LadderEX® Retract-A-Stiles
36	SAFE-SERIES™ Anti-Slip Safety Solutions
37	ArchitEX™ Composite Structural FRP
38	ArchitEX™ FRP Profiles
39	TreadSLAB® Panel Types Available
40	Case Study – Purlin Replacement
41	Our Partners



## Quality Policy

Quality is at the forefront of Treadwell's working practices. With over 15 years of manufacturing to the highest quality standards, Treadwell prides ourselves on our reputation for implementing strict quality control measures, and strives to supply products that surpass customers expectations. The company works on a policy of 'continuous improvement'.



## Environment Policy

Treadwell is conscious of the impact it has on the environment and its associated responsibilities. The company is committed to ensuring its operations satisfy legal obligations and other responsibilities. Treadwell remains committed to sustainability.

**Disclaimer:** The information contained in this Treadwell design guide herein supplied is as a service to our customers and is intended to be used only as a general guide. It is not a substitute for proven engineering practices and designs.

## What You Get When You Work with Treadwell

### Specialised Online Tools

Conveniently located online, our selection tool allows users to fill in selection criteria based on each product brand we carry and will recommend a product suitable to your needs. Our product information has been imprinted on the tool to provide ease of outline and inspiration to architects, engineers, designers and other users. Users can also find all our product files in PDF, DWG, STEP etc. files to download for each of our products.

Visit our website at <https://www.treadwellgroup.com.au/treadspec/> to try out these online specifier tools.



### Friendly & Professional Design Support

Whether you're looking to upgrade or completely revamp your rail infrastructure assets, we can help support your design services across all stages of your project lifecycle. Our qualified and experienced engineering team have provided turnkey as well as purely design-based projects. With a knowledgeable team, we are able to provide solutions to fit your requirements.



### Cutting Edge Technical Information

Treadwell has a LEAN manufacturing facility, approximately 4000m<sup>2</sup> under one roof. Our automated CNC equipment, including state-of-the-art 90,000 PSI waterjet cutting system and beam line ensures minimal material wastage, and as such, eliminates excessive costs. Our internal design engineering department is able to provide design expertise and sign off engineering in all states of Australia (RPEQ and NT certified), and an on-site Quality Assurance team to perform the necessary checks.



With our well-established partnerships with logistics partners across Oceania, complemented by our own fleet of trucks and trailers in Australia, we are able to deliver your projects across the region efficiently and effectively on time and in full.

# Bespoke & Specialised Projects - Our Process Explained

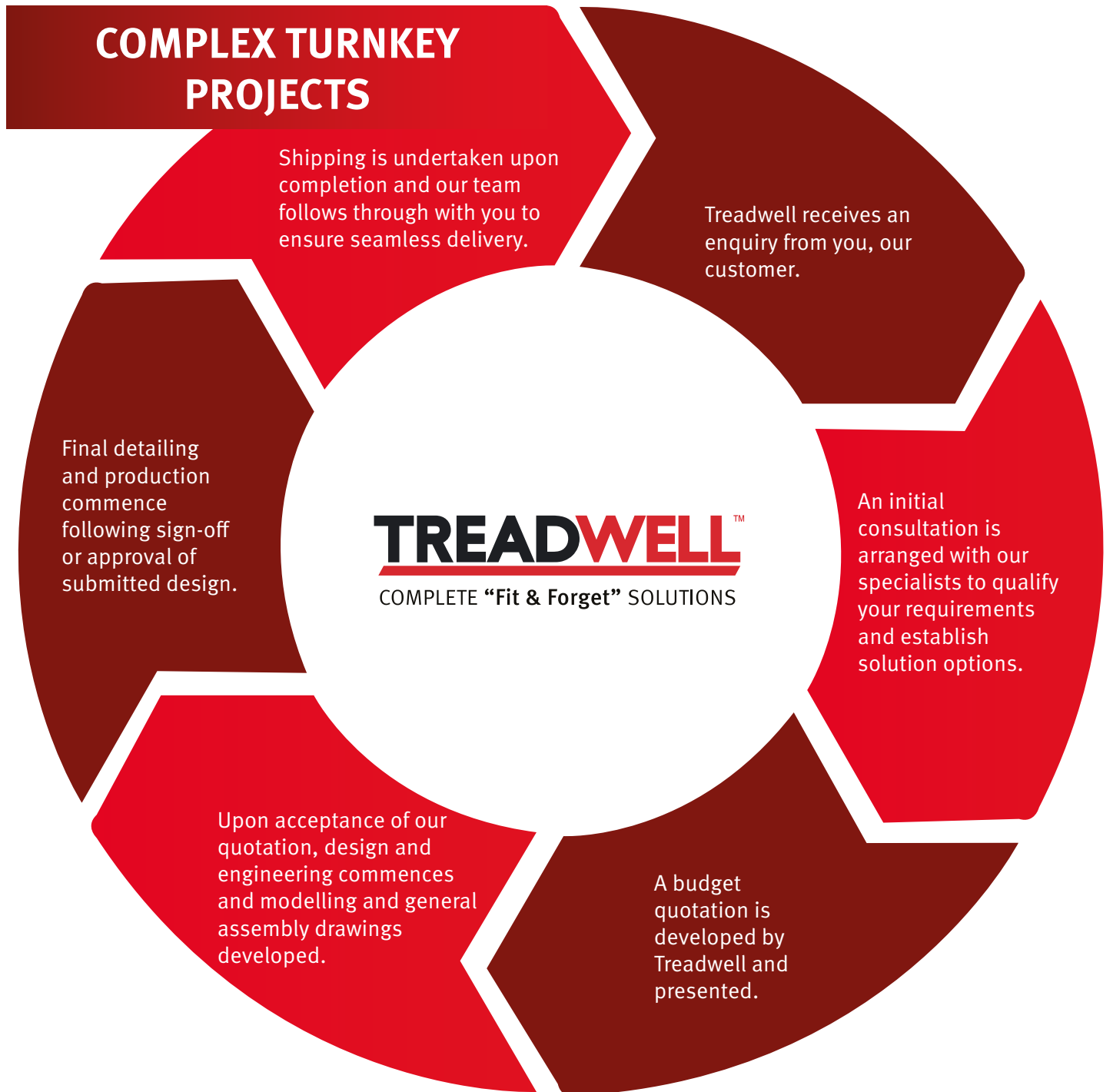

## Why Choose Treadwell?

- 1 Our team of engineers are available to support your design requirements by providing technical expertise and specifications.
- 2 Our products are tested and meet relevant compliant codes where required.
- 3 We offer solutions based on practical calculations and data, providing the optimum products for your application.
- 4 We are an established name in Australia for providing durable and dependable FRP solutions.





Dampier, Western Australia - Dampier Salt Mine

## What is EX-Series® FRP Grating?

Treadwell's GratEX® moulded FRP grating is a high strength, single piece construction mesh panel product. Treadwell offers both standard panel sizes as well as the option of custom panels made to order from your drawings, or alternatively, drawings provided by Treadwell's drafting department.

Cost effective GratEX® panels allow for effective on-site fabrication/trimming whilst ensuring that wastage is minimised. Load bearing bars in both directions allow for use without continuous side support and so contribute to cost effectiveness. GratEX® offers all the benefits available with grating made from other materials plus a host of superior benefits unequalled by steel or other metal alternatives.



### GratEX® Surface Options

**Anti-Slip Surface (Standard).** This surface is most commonly used in industrial applications. It is very hard wearing and boasts an extremely effective coefficient of friction (NATA laboratory test report available). Unlike serrated steel, the anti-slip surface does not impact load carrying capacity.

**Concave Surface.** This is preferred for environments where by-products are commonly caught by serrations, and is hence very often utilised by the food industry. This surface option can also be used for guarding options to allow safe handling/ contact.

**Plain Surface.** This is a stock option that is widely utilised for guarding and architectural features in a variety of applications. Whilst the aesthetics of the product are improved, the anti-slip properties are not as profound as the other options available.





# Treadwell EX-Series® FRP Grating

Treadwell EX-Series® Fibreglass Reinforced Plastics (FRP) grating products are recommended for areas where physical properties are paramount to design and longevity. Treadwell offers an extensive range of FRP grating products, two of which are highly utilised in the rail industry. There are key differences to take note of. The information below outlines the key differences and the ideal scenarios in which the different types of grating are to be utilised.

## GratEX® Moulded FRP Grating

The perfect solution for areas where excessive amounts of penetrations (i.e. for piping) call for traditional uni-directional spanning products. This greatly increases the costs when using traditional materials, like steel. FRP grating maintains strength and integrity even with multiple penetration cut outs, while keeping costs low.

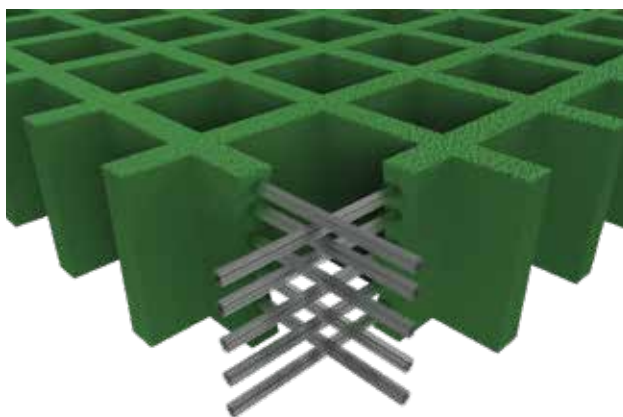

## GridEX® Pultruded FRP Grating

The ultimate choice for areas where extremely high loadings, or larger spans present a challenge. Such applications include wide walkways, or where equipment needs to be installed on top of grating.

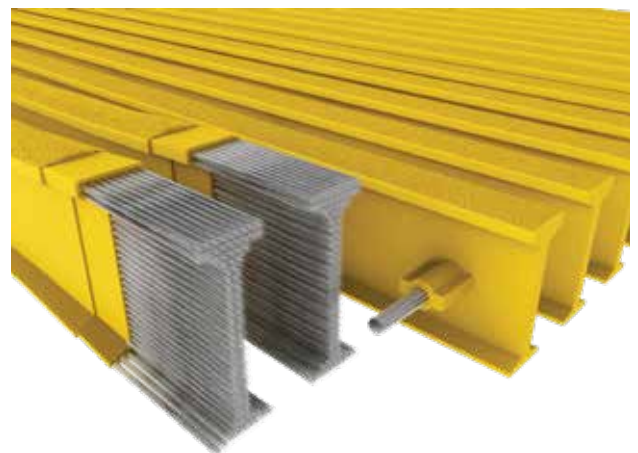

**Please consult our EX-Series® Grating Product Guide for more information.**









**GratEX® Clip - Tops**

STANDARD M	MINI MESH M	MINI MESH M (SLOTTED)	C	L
Hole Diameter: 8mm Material type: 316 st/st Threaded hole: N/A	Hole Diameter: 6mm (8mm for GTX-502525M1) Material type: 316 st/st Threaded hole: N/A	Hole Diameter: 6mm Material type: 316 st/st Threaded hole: N/A	Hole Diameter: 6mm Material type: 316 st/st Threaded hole: Yes	Hole Diameter: 6.5mm Material type: 316 st/st Threaded hole: N/A
				

D	E	W	S	O
Hole Diameter: 8.5mm, 7mm Material type: 316 st/st Threaded hole: N/A	Hole Diameter: 8mm Material type: 316 st/st Threaded hole: N/A	Hole Diameter: 8mm Material type: 316 st/st Threaded hole: N/A	Hole Diameter: 8mm Material type: 316 st/st Threaded hole: N/A	Hole Diameter: 8mm Material type: 316 st/st Threaded hole: N/A
				

**Clamp Underside**

J - UNIVERSAL	J - MINI-MESH	H
Hole Diameter: N/A Material type: 316 st/st Threaded hole: N/A	Hole Diameter: N/A Material type: 316 st/st Threaded hole: N/A	Hole Diameter: 8mm Material type: st/st Threaded hole: Yes
		

G	U	V	T
Hole Diameter: 6mm, 8mm Material type: st/st Threaded hole: Yes	Hole Diameter: 8mm Material type: 316 st/st Threaded hole: Yes	Hole Diameter: 8mm Material type: 316 st/st Threaded hole: N/A	Hole Diameter: N/A Material type: 316 st/st Threaded hole: N/A
			

## Case Study – Lithium Processing Plant



PROJECT INFORMATION	
Project Category:	Mineral Processing Plant
Scope of Work:	Supply FRP grating
Treadwell Products:	EX-Series® GratEX® FRP Square Mesh Grating EX-Series® GridEX® FRP I-Type Grating EX-Series® GridEX® FRP Solid Top Grating

Based in Western Australia, this lithium hydroxide processing plant is the first to produce battery grade lithium in commercial quantities for the electric vehicle industry. A top-tier production plant in terms of scale and technology, the construction of this plant required various types of grating installed at different parts of the structure.

Treadwell was engaged to supply the required grating.



### Treadwell's Solution:

- 1

GratEX® FRP Square Mesh grating is easily customised, hardwearing and features excellent co-efficient of friction.

---

- 2

GridEX® FRP I-Type grating is manufactured and designed with the structural integrity associated with metal grating systems, without the associated corrosion problems. This pultruded grating includes high resistance to fatigue.

---

- 3

GridEX® FRP Solid Top grating includes all the features of the I-Type grating, with a solid top deck. This was installed in areas where the apertures in the grating were not required.

---

- 4

Treadwell FRP grating addressed corrosion concerns.

---

- 5

FRP is easily installed without the need for heavy machinery, and any variance on tasks is managed with hand tools, eliminating the need for any hot works permit.

## Case Study – Copper Concentrate Processing Plant



PROJECT INFORMATION	
Project Category:	Mineral Processing Plant
Scope of Work:	Supply FRP products
Treadwell Products:	EX-Series® GratEX® FRP Mini Mesh Grating EX-Series® GratEX® FRP Square Mesh Grating & Stair Treads

South Australia – Located approximately 160km from Port Augusta, this mine is one of the biggest underdeveloped copper projects in Australia. After delays caused by the COVID-19 pandemic, expansions plans were finally approved in 2021. This will increase production to 12 million tonnes per annum by 2023.

Treadwell was engaged to supply the grating and stair treads for the expansion plans.



### Treadwell's Solution:

- 1

GratEX® FRP Stair Treads are constructed with a solid nose leading edge. This increases the rigor and sturdiness of the entire leading edge, ensuring dependable performance in high traffic situations.

---

- 2

GratEX® FRP Square Mesh grating allows maximum debris to fall through, eliminating the risk of matter build up, with a self-maintaining anti-slip surface for maximum user safety.

---

- 3

GratEX® FRP Mini Mesh grating has apertures to allow water to fall through, eliminating the risk of stagnant water and creating a self-maintaining anti-slip surface.

---

- 4

Constructed from premium resin systems, Treadwell's FRP grating is corrosion resistant, with fire retardant properties, as well as UV inhibitors, making it ideal for this outdoor and corrosive environment.

## Case Study – Zinc Processing Plant



PROJECT INFORMATION	
Project Category:	Mineral Processing Plant
Scope of Work:	Supply FRP grating
Treadwell Products:	EX-Series® GratEX® FRP Square Mesh Grating

Northern Territory – Located on one of the world’s largest deposits of zinc and lead, mining site includes an open cut mine and processing facilities. In these corrosive manufacturing conditions, a high performance, long lasting and durable product was required for the decking for the facilities.

Treadwell was engaged to supply the FRP grating to meet these requirements.



### Treadwell's Solution:

- 1

GratEX® FRP Square Mesh grating is extremely versatile, with a high strength to weight ratio, presenting as the ideal high-performance alternative to steel.

---

- 2

GratEX® FRP grating is corrosion resistant, and minimises mechanical damage during removal.

---

- 3

Easily clipped into place with hand tools, GratEX® FRP grating is also easily removed when needed for access to repairs and maintenance requirements.

## Case Study – Salt Wash Plant Screen Guards



PROJECT INFORMATION	
Project Category:	Mineral Processing Plant
Scope of Work:	Supply FRP grating
Treadwell Products:	EX-Series® GratEX® FRP Square Mesh Grating & Stair Treads

Shark Bay, Western Australia – Our client was contracted to review a salt mining company’s pilot plant, with a view to upgrade their existing salt wash plant. The new plant would provide increased throughput, similar recoveries, a more reliable plant and increased life expectancy.

Treadwell was engaged to provide the FRP grating for the decking and screen guards.



### Treadwell's Solution:

- 1

EX-Series® GratEX® FRP stair treads are moulded with the solid leading edge as a joint single stage component. This increases the rigor and sturdiness of the entire leading edge, ensuring dependable performance in high traffic situations.

---

- 2

GratEX® FRP Square Mesh Grating panels are designed to be high strength and made as a single piece construction mesh panel. This helps with easy installation.

---

- 3

Treadwell's FRP is corrosion resistant, with RF transparent properties, making it ideal for this application.

## Case Study – Metals Mining Facility



PROJECT INFORMATION	
Project Category:	Mineral Producing Plant
Scope of Work:	Supply FRP grating
Treadwell Products:	EX-Series® GratEX® FRP Square Mesh Grating

Roxby Downs, South Australia – This mine is one of the world’s most significant deposits of copper, gold and uranium. Made up of underground and surface operations, this mine site has a fully integrated processing facility from ore to metal.

As part of maintenance, the decking in some areas the facility needed to be replace. Treadwell was engaged to supply the FRP grating.



### Treadwell's Solution:

- 1

Treadwell’s team of engineers are skilled in ensuring grating deflection meets the relevant compliance codes and industry standards.

---

- 2

EX-Series® GratEX® FRP Square Mesh grating allows for maximum flow through of debris, while remaining anti-slip for user safety.

---

- 3

With a ready stock of GratEX® grating panels, repairs and replacements, if any, are easily managed.

## Case Study – Gold Mine Facility



PROJECT INFORMATION	
Project Category:	Mineral Processing Plant
Scope of Work:	Supply FRP grating
Treadwell Products:	EX-Series® GratEX® FRP Solid Top Grating

Kalgoorlie, Western Australia – One of Australia’s largest open pit gold mines, this mining operation is a world class asset located adjacent to the City of Kalgoorlie-Boulder. Operations include an underground mine and processing plants.

Treadwell was engaged to supply FRP solid top grating as part of their structural works.

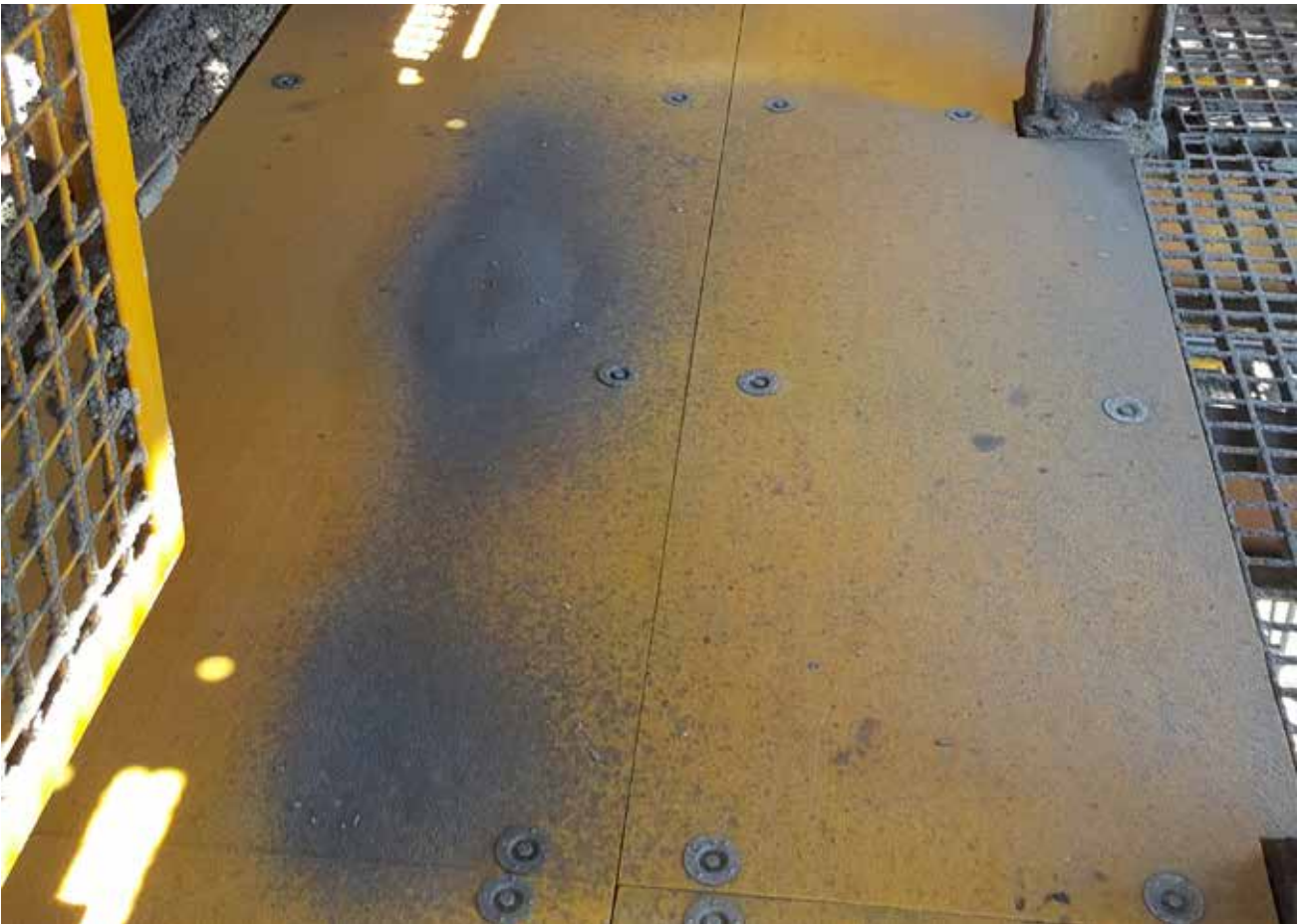

### Treadwell's Solution:

- 1** EX-Series® GratEX® FRP solid surface grating is based on the standard square mesh with a covered solid top, this is ideal in areas where openings in the grating are not required, or create concerns for users.
- 2** Treadwell's FRP products meet the relevant Australian standards and compliance codes, ensuring dependability, even in harsh conditions.





Western Australia - Nickel Processing Plant

## What is RailEX® ROUND Tubular Handrail?

Treadwell's RailEX® ROUND Tubular Handrail is an industrial rated composite handrail system which combines strength, durability and versatility meaning the system is ideal for use in numerous applications in a vast range of industries. Treadwell can supply RailEX® as either components or as fabricated handrail panels ready for installation.

### Smart Transposable Designs

Unlike traditionally welded alternatives, Treadwell FRP handrail system dispenses the need for drafting, engineering and onsite fabrication while minimising installation costs. Treadwell's safety handrail systems can be adapted or extended with additional components, or cut to size onsite. Pre-engineered kits are supplied as a series of components with simple assembly instructions. With our clients in mind, Treadwell aims to minimise the cost of maintenance and repairs, and damaged components easily with readily available parts and stock.

### Simple Zero Weld Assembly

As an added benefit, fibreglass handrail kits are assembled using a simple, zero weld construction method; reducing the chances for corrosion activation. Treadwell's RailEX® designs and fittings effectively eliminate the need for specialist trades, hot works permits, fire spotters and welding protection to finished surfaces. Our selection of FRP increases safety conditions for installers by eliminating toxic fumes, welding in wet areas and fire risk hazards.

Developed by Treadwell with the input of designers, and plan operators, this system offers you all benefits of traditional guardrail systems without the inherent problems - corrosion, welding and hot works permits for onsite modifications. This unique system is a first to be tested and conform with Australian Standards AS 1657. RailEX® is the **'Fit & Forget'** handrail system.



This product conforms to AS1657



## RailEX® Features and Benefits vs. Traditional Alternatives

	RailEX®	Stainless Steel	Galvanised Steel	Aluminium	Timber
Chemical Resistance	•••••	•••••	•	•••	•••••
Strength	•••••	•••••	•••••	•••••	••
Lightweight	•••••	•	•	•••••	••
Electrical Resistance	•••••	•	•	•••••	•••••

## Materials of Construction

RailEX® FRP handrail is constructed from fibreglass rovings combined with a blend of thermosetting resin systems. All of the resins used in the production of EX-Series® products contain UV inhibitors and fire retardant additives.



# RailEX® ROUND Overview

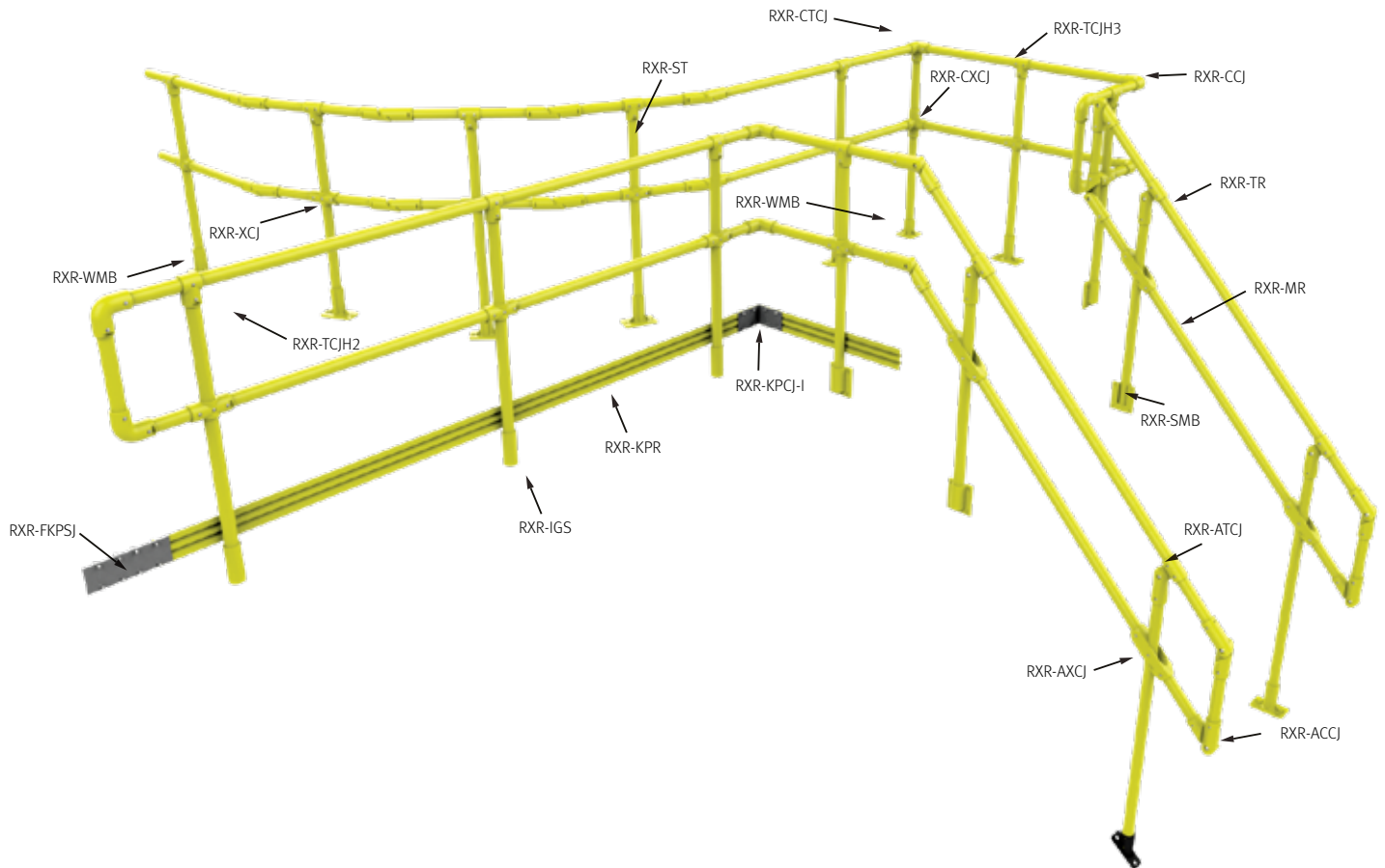

**Please consult our RailEX® Handrail Installation and Product Guides for more information.**



## RailEX® ROUND Stanchion Kits & Handrail Parts

Treadwell has created options of RailEX® handrail stanchion kits. This ensures that all the required parts are included, making for easy planning and installation. Please note that the list below is just a selection of our most popular handrail assemblies. For a more comprehensive selection, please consult our RailEX® Product Guide .

RXR-SN-VY-K	RXR-SS-VY-K	RXR-AA-VY-K	RXR-AS-VY-K
<p>RailEX® ROUND Stanchion Sales Kit, Standard Stanchion with Narrow Mounting Bracket, V-Series® Safety Yellow, including Stainless Steel Fasteners.</p> <p>NOTE: Assembly excludes fasteners to connect to structure.</p>	<p>RailEX® ROUND Stanchion Sales Kit, Standard Stanchion with Side Mounting Bracket, V-Series® Safety Yellow, including Stainless Steel Fasteners.</p> <p>NOTE: Assembly excludes fasteners to connect to structure.</p>	<p>RailEX® ROUND Stanchion Sales Kit, Adjustable Stanchion with Angled Round Top Mount Bracket, V-Series® Safety Yellow, including Stainless Steel Fasteners.</p> <p>NOTE: Assembly excludes fasteners to connect to structure.</p>	<p>RailEX® ROUND Stanchion Sales Kit, Adjustable Stanchion with Side Mounting Bracket, V-Series® Safety Yellow, including Stainless Steel Fasteners.</p> <p>NOTE: Assembly excludes fasteners to connect to structure.</p>
<p>RXR-CC Standard ROUND Fibreglass 90° Corner Connection Joint</p>	<p>RXR-XCJ Standard ROUND Fibreglass Cross Connection Joint</p>	<p>RXR-TCJH2 Standard ROUND Vertical Fibreglass Connection Joint</p>	
<p>RXR-TCJH3 Standard ROUND Horizontal Fibreglass Tee Connection Joint (three holes)</p>	<p>RXR-TRJ Standard ROUND Fibreglass Top Rail Joiner</p>	<p>RXR-ACCJ Adjustable ROUND Fibreglass Corner Joint</p>	
<p>RXR-AXCJ Adjustable ROUND Fibreglass Cross Connection Joint</p>	<p>RXR-ATCJ Adjustable ROUND Fibreglass Tee Connection Joint</p>	<p>Standard Stainless Steel Driver Kit M6 Type with Trilobular Head</p>	
<p>RXR-SMB Standard ROUND Fibreglass Side Mounting Bracket</p>	<p>RXR-NMB Standard ROUND Fibreglass Narrow Mounting Bracket</p>	<p>Standard Stainless Steel Fastener Kit M6 with Trilobular Head (stock item)</p>	<p>Standard Stainless Steel Fastener Kit M10 (stock item)</p>

## Case Study – Port Latta Iron Export Site



PROJECT INFORMATION	
Project Category:	Iron Ore Production Facility
Scope of Work:	Supply FRP products
Treadwell Products:	EX-Series® GratEX® FRP Grating EX-Series® RailEX® Round Handrail

The iron ore production facility in Port Latta is one of Australia’s largest and has been serving global markets for many decades. Set to increase its annual production of iron pellets in the coming years, this production plant is not slowing down.

To ensure the safety of their workers, Treadwell was engaged to provide safe access in the production facility. Keeping in mind the projected high levels of productivity, it was specified that the products used would be quick to install and would not require regular downtime for maintenance.

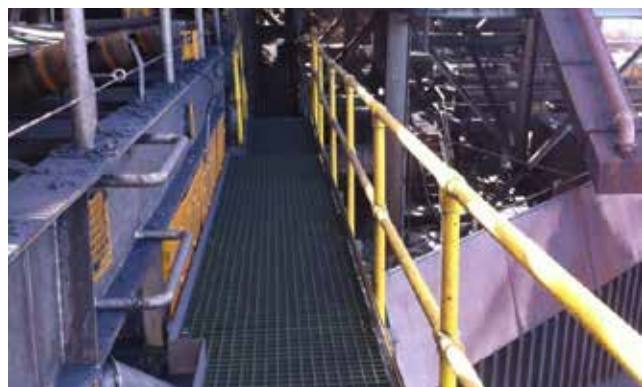

### Treadwell's Solution:

- 1

GratEX® FRP Grating is constructed with an anti-slip surface, providing superior slip resistance.

---

- 2

RailEX® Round handrails provide dependable and safe support.

---

- 3

FRP is simply fabricated and modified on site. This means there is no need for any hot works permit.

---

- 4

Being lightweight and easy to install, FRP is very manageable during construction.

---

- 5

Given the nature of FRP, any system utilizing it is virtually maintenance free, keeping maintenance costs to a minimum.

## Case Study – Nickel Processing Plant



PROJECT INFORMATION	
Project Category:	Mineral Processing Plant
Scope of Work:	Supply FRP handrail
Treadwell Products:	EX-Series <sup>®</sup> RailEX <sup>®</sup> ROUND FRP Handrail

Based in Western Australia, this is Australia’s leading nickel producer with two of the highest-grade nickel mines in the world. As a publicly listed company, they are focused on safely, sustainably and ethically delivering products to advance the global transition to decarbonization. As part of upgrading works at this processing plant, the existing handrails needed to be replaced.

Treadwell was engaged to supply the FRP handrails, to be retrofitted to the existing structure.



### Treadwell's Solution:

- 1** EX-Series<sup>®</sup> RailEX<sup>®</sup> FRP handrails are assembled using a zero-weld method of putting the system together, which greatly minimises the chances of corrosion.
- 2** RailEX<sup>®</sup> FRP handrails are lightweight and can be installed without the need for heavy tools, making it ideal for this retrofit application.
- 3** RailEX<sup>®</sup> FRP handrails are constructed from premium resin systems, with corrosion resistant properties, as well as being rot- and termite-proof.

## Case Study – Tailings Pump Station



PROJECT INFORMATION	
Project Category:	Mineral Processing Plant
Scope of Work:	Supply FRP handrail
Treadwell Products:	EX-Series® RailEX® SQUARE FRP Handrail

South Australia – This ore processing plant had an expansion plan in place to increase their production capabilities. Our client was contracted to construct a new storage facility including the related fabrication and installation of pipes, instrumentation, valves and pumps.

Treadwell was engaged to supply the FRP handrails for this expansion.



### Treadwell's Solution:

- 1

EX-Series® RailEX® FRP handrails are constructed with UV Inhibitors and fire retardant properties.

---

- 2

RailEX® FRP handrails is the choice alternative to metallic handrails and offers radio frequency transparency, while being non-conductive in nature.

---

- 3

RailEX® FRP handrails have low thermal conductivity making it ideal for this outdoor application.

## What is EX-Series® Industrial Composite Solutions?

A designed composite structural and access solution featuring a combination of our FRP products.

These access structures are easily installed in elevated, remote, indoor or outdoor locations, and possess corrosion resistant and low electrical conductivity properties.



### FIXED STAIRCASES

An FRP solution featuring a combination of ArchitEX™ structural profiles, EX-Series® grating and stair treads, and RailEX® handrails. Built to withstand corrosive indoor and outdoor environments.

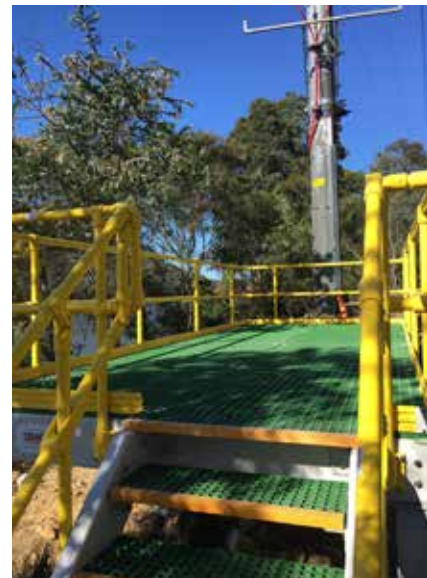

### FIXED ACCESS PLATFORMS

These can be customised to the span required for its purpose. Being naturally non-conductive, FRP is a cost-effective and long-lasting solution for electrically sensitive environments.



### FIXED STEPOVERS

All GratEX® and MoultrEX® premium and standard Stair Tread options are moulded with the solid leading-edge nosing as joint single stage component. This increases the rigor and sturdiness of the entire leading edge ensuring dependable performance in high traffic situations. All the treads with abrasive leading-edge nosings are manufactured to conform to AS 1657 – 2018.



### RAIL PLATFORMS

Treadwell's TreadSLAB® FRP panels are constructed with an anti-slip surface and corrosion resistant properties. This maintains optimal user safety. Panels can also be customised according to load requirements.



## Case Study – Chemical Manufacturing Plant



PROJECT INFORMATION	
Project Category:	Chemical Manufacturing Plant
Scope of Work:	Supply EX-Series® FRP Solution
Treadwell Products:	EX-Series® GratEX® FRP Square Mesh Grating EX-Series® RailEX® ROUND Handrails ArchitEX™ secondary framing & joists

A diversified chemical manufacturer, this proudly Australian owned company has multiple plants in Australia and Malaysia. Established in the early 1970s, they have come a long way and have expanded their portfolio over the years. In addition to chemical manufacturing, their capabilities include related bulk chemical and fuels storage and handling, as well as terminal infrastructure management. One of their major business commitments is the focus on operational safety.

As part of the extension of their plant in Brisbane, Treadwell was engaged to supply the FRP grating and handrails.



### Treadwell's Solution:

- 1

Treadwell's EX-Series® GratEX® FRP grating and RailEX® ROUND handrails ensure durability with built-in corrosion resistant properties.

---

- 2

Treadwell's ArchitEX™ secondary framing and joists are non-conductive and non-corrosive, making it ideal for this application.

---

- 3

With a ready stock of GratEX® grating panels and RailEX® parts, repairs and replacements, if needed, are easily managed.

---

- 4

GratEX® stair treads moulded with a solid leading-edge stair nosing were used. This increases the rigor and sturdiness of the entire leading edge, ensuring dependable performance in high traffic situations.

---

- 5

FRP is simply fabricated and modified on site. This means there is no need for any hot works permit.

---

- 6

Being lightweight and easy to install, FRP is very manageable during construction.

## Case Study – FRP Pump Support & Access Structure



PROJECT INFORMATION	
Project Category:	Mining Infrastructure
Scope of Work:	Supply EX-Series® FRP Solution
Treadwell Products:	EX-Series® GratEX® FRP Square Mesh Grating EX-Series® RailEX® ROUND FRP Handrail ArchitEX™ FRP Structural Profiles

Kalgoorlie, Western Australia – This fully Australian owned gold mine facility is a world class asset located adjacent to the City of Kalgoorlie-Boulder, approximately 600km east of Perth. The 1893 gold rush resulted in the discovery of the Golden Mile, one of the richest gold deposits in the world, producing more than 60 million ounces of gold.

As part of upgrades, pump support and access structures were needed for a Warman pump. Treadwell was engaged to supply the FRP products for these upgrades.

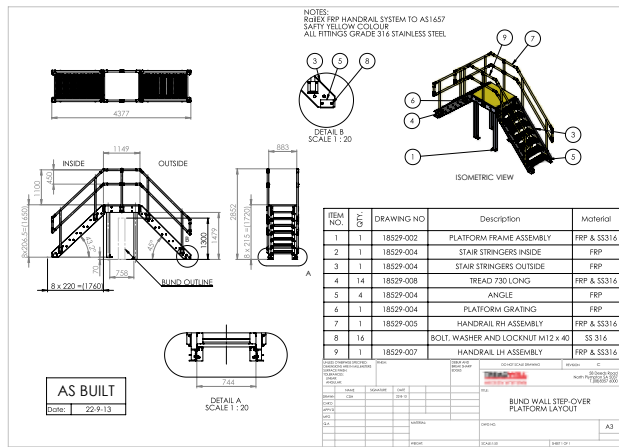

### Treadwell's Solution:

- 1 The resin systems used in Treadwell's FRP products are customised to suit its application. This includes corrosion resistant properties, with a fire retardant formula.
- 2 The aperture of the GratEX® FRP Square Mesh allows maximum fall through of debris, minimising the impact of stagnant debris.
- 3 Treadwell's FRP products are RF transparent and has low thermal and electrical conductivity, ensuring user safety.
- 4 FRP is simply fabricated and modified on site. This means there is no need for any hot works permit.
- 5 Being lightweight and easy to install, FRP is very manageable during construction.

## Case Study – Mineral Processing Plant Cooling Tower



PROJECT INFORMATION	
Project Category:	Mineral Processing Plant
Scope of Work:	Supply EX-Series® FRP Solution
Treadwell Products:	EX-Series® GratEX® FRP Square Mesh Grating & Stair Treads EX-Series® RailEX® ROUND FRP Handrail ArchitEX™ FRP Structural Profiles

Based in South Australia, this is a fully integrated processing facility of minerals from ore to metal. As part of operations, this mineral processing plant needed a new cooling tower installed, and their existing cooling tower to be decommissioned and demolished.

Treadwell was engaged to supply the FRP products.



### Treadwell's Solution:

- 1

GratEX® FRP Stair Treads are constructed with a solid nose leading edge. This increase the rigor and sturdiness of the entire leading edge, ensuring dependable performance in high traffic situations.

---

- 2

GratEX® FRP Square Mesh grating allows maximum debris to fall through, eliminating the risk of matter build up, with a self-maintaining anti-slip surface for maximum user safety.

---

- 3

ArchitEX™ FRP Structural Profiles are manufactured from a pultrusion process, specifically designed to endure all sorts of environmental inconsistencies.

---

- 4

Treadwell's FRP products are constructed from premium resin systems with corrosion resistant and fire retardant properties, as well as UV inhibitors, making it ideal for this application.

## Case Study – Salt / Bitterns Discharge Winch Tower & Bridge



PROJECT INFORMATION	
Project Category:	ArchitEX™ structure
Scope of Work:	Design & supply EX-Series® FRP Solution
Treadwell Products:	ArchitEX™ FRP Structural Profiles EX-Series® GratEX® FRP Square Mesh Grating EX-Seires® RailEX® ROUND FRP Handrail

Particular attention had to be paid to the extremely corrosive environment the winch tower would sit in – this meant that the majority of conventional materials would be eliminated for selection.

Our client’s engineering team worked in close conjunction with our FRP design and development personnel throughout the whole project to build a lightweight, corrosion resistant and cyclone rated structure that was capable of supporting a heavy duty winch with a S.W.L. of 5 tonnes. The resulting construction consisted of all members made of Fibreglass, joined together using 316 grade stainless steel bracketry

As it was necessary to have personnel access on the winch, a bridge section was developed to span the 7 metres between a bank of earth and the tower. GratEX® was used to make certain that all personnel accessing the tower would enjoy safe and secure footing in conjunction with RailEX®, Treadwell’s FRP hand railing system.

The structure was fully trial assembled and then partly dismantled and packed into modules to be delivered on time in full.

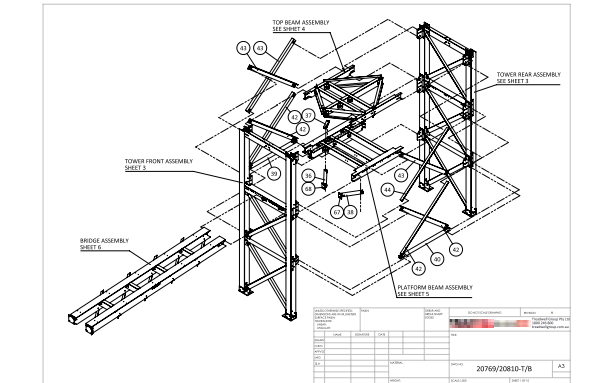

### Treadwell's Solution:

- 1

ArchitEX™ FRP columns, beams and other supporting profiles were specified as the skeleton of the structure. GratEX® FRP grating and RailEX® FRP handrail were supplied to provide safe access. Specially formulated resin was categorically determined to withstand the corrosion.

---

- 2

The ArchitEX™ profiles were tested to be cyclone rated.

---

- 3

Being lightweight and easy to install, FRP is very manageable during construction.

---

- 4

Given the nature of FRP, any system utilising it is virtually maintenance free.

---

- 5

FRP is high in strength. Based on the resin formula and engineered design, the structure was capable to support the heavy duty winch.



R  
UT  
SS

**DANGER**  
NO CUTTING  
NO WELDING

**DANGER**  
FLAMMABLE  
MATERIALS

**DANGER**  
NO CUTTING  
NO WELDING  
WITHOUT PERMIT



**ABUSE POWDER**



South Australia - Mineral Processing Plant

### EXduro™ Cable Ladders





For environments where corrosive elements play a crucial part in a material, Treadwell has developed its FRP cable ladders as a strong support solution as the alternative to metal cable ladders. Being lightweight, it allows for easier installation or onsite fabrication as well as giving the cable ladder a high strength to weight ratio.

EXduro™ fibreglass cable ladders has several other benefits that may be useful. It is both a UV resistant and fire retardant system. Transparent to RF frequencies and electrically non-conductive are other positives it can bring to any design.

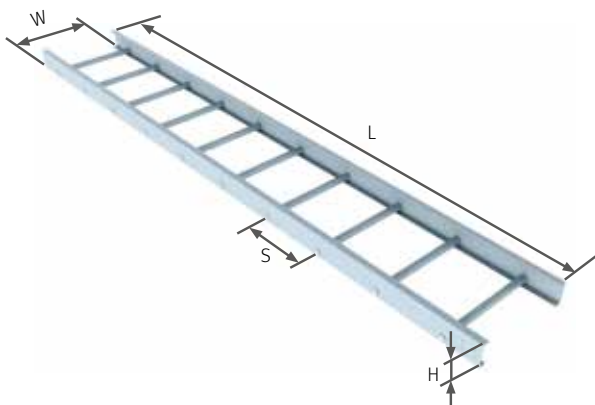
EXduro™ fibreglass cable ladders are also a cost competitive, performance proven alternative to metal systems for that corrosive/chemical environment to run your electrical cable and instrumentation pipe work. With minimal to no ongoing maintenance, Treadwell's system is supplied with both FRP and stainless steel fasteners to suit your application.

F-EXD-CL-C(H)(W)-(R)(S)-(RS)(C)-(L)						
Side Rail Height (H)	Width (W)	Rung Type (RT)	Rung Spacing (S)	Resin (RS)	Colour (C)	Length (L)
50mm (050)	150mm (150)	Standard Rung (S)	150mm (150)	Standard Polyester (SI)	Light Grey (LG)	3m (1) N
75mm (075)	300mm (300)	Marine Rung (M)	250mm (250)	Standard Vinylester (SV)	Custom Colour (CC)	6m (2) C
100mm (100)	450mm (450)		300mm (300)	Conductive Polyester (CI)		
150mm (150)	600mm (600)		450mm (450)	Conductive Vinylester (CV)		
200mm (200)	750mm(750)			Halogen free Polyester (HI)		
	900mm (900)			Halogen free Vinylester (HV)		
				Halogen free Low Smoke Plus (HF)		



Straight splice plate	90 Vertical splice plate
	
Adjustable vertical splice plate	Adjustable Horizontal splice plate
	

### Cable Ladder Splice Plates

Our splice plates are available in both horizontal and vertical degree sections. We also offer the accompanying accessories separately. We construct both flat and peaked covers. These plates are non-conductive and do not react on electric and magnetic fields.

## Case Study – Zinc Refinery Plant



PROJECT INFORMATION	
Project Category:	Mineral Processing Plant Cable Management
Scope of Work:	Supply FRP cable ladders
Treadwell Products:	EXduro™ FRP Cable Ladder

Townsville, Queensland – This zinc refinery produces a special grade of zinc metals. Secondary products produced include Sulphuric acid, low grade zinc concentrate and copper cake. These products are then sold to the international and domestic markets.

As part of upgrading works to the refinery, this processing plant required an organised method of running their electrical cables. Treadwell was engaged to supply our EXduro™ FRP cable ladders for this purpose.



### Treadwell's Solution:

- 1

EXduro™ FRP Cable Ladders, Trays and Instrument Stands do not rust even in constant exposure to various oxidising conditions.

---

- 2

EXduro™ FRP products can be customised to fit the application, and various resins systems can be utilised to provide optimum performance.

---

- 3

EXduro™ FRP products are lightweight, which reduces costs for transport, and can be easily installed without the need for heavy machinery, further minimising total costs.

---

- 4

Given the nature of FRP, any system utilising it is virtually maintenance free, keeping maintenance costs to a minimum.

## Case Study – Solar Salt Processing Plant



PROJECT INFORMATION	
Project Category:	Mineral Processing Plant
Scope of Work:	Supply FRP products
Treadwell Products:	EX-Series® GratEX® FRP Square Mesh Grating & Stair Treads EXduro™ FRP Cable Ladders EX-Series® RailEX® ROUND FRP Handrails ArchitEX™ FRP Structural Profiles

Western Australia – This solar salt plant is part of a group of three sites that is the world’s largest exporter of seaborne salt, with the capacity to produce approximately 10.3 million tonnes every year. Natural energy from the sun and wind is harnessed for sale production.

Treadwell was engaged to supply the FRP grating and cable management systems for this salt mine.



### Treadwell's Solution:

- Constructed from premium resin systems, Treadwell's FRP products are corrosion resistant, with fire retardant properties, as well as UV inhibitors, making it ideal for this outdoor and corrosive environment.
- Treadwell's unique surface finishing system ensures UV stability in exposed applications, directly eliminating the need for costly surface treatments.
- FRP is manufactured from a more economically sound raw material base than metallic alternatives, and is far more structurally sound when compared to timber and plastic materials.





Queensland - Mineral Processing Plant

## What is EX-Series® LadderEX® FRP Ladders?

**LadderEX® is the superior alternative to metallic ladders and cage systems, providing excellent corrosion resistance and electrical transparency. Even in complete immersion applications, Treadwell's fibreglass ladders have outlasted aluminium and steel, and required little or no maintenance.**

Our products in this range are made from superior fibreglass which offers unparalleled advantages, leaving behind alternatives that are metal or steel based. Our ladders and ladder cage systems are produced using a premium grade polyester resin system with flame retardant and ultraviolet (UV) inhibitor additives. A vinyl ester resin system is available upon request for additional corrosion resistance. Standard side rails and cages are in safety yellow. The rungs are a pultruded fibreglass polyester tube with a fluted, non-skid surface.

LadderEX® fibreglass ladder systems are fabricated and designed with FRP according to AS 1657-2018. The pultruded parts are produced with a fire retardant polyester resin which meets the ASTM E-84 test for flame spread of 25 or less and contains a UV inhibitor. The colour is in standard OSHA safety yellow though colour matching can be provided.

Ladders are shop assembled and may be pre-drilled and prepared for field attachment with standoff clips and/or base brackets systems.

The LadderEX® product range can easily be integrated into any existing platform or structure. It can come in a variety of configurations to suit any purpose as well.



### LadderEX® Standard Ladder with ROUND Grab Stiles

LDX-RG

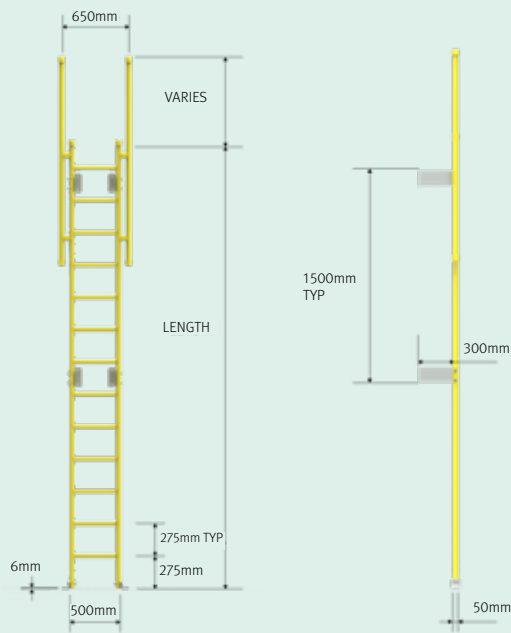

**Brief:**  
In instances where there is a requirement for extra security above 1.5m, Treadwell can supply standard access ladders without returns with a round grab stile.

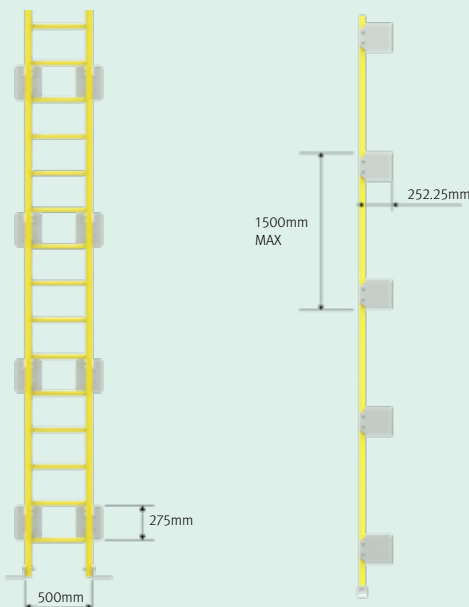

**Please consult our LadderEX® Product Guide for more information.**

LadderEX® Heavy Duty Wall Mounted SQUARE Ladder	LDX-SL
	
<p><b>Brief:</b> For industrial and other heavy duty purposes, Treadwell supplies a more durable and robust heavy duty wall mount and floor mounts (if required) for that added safety factor.</p>	

## **R**ETRACT-A-STILES

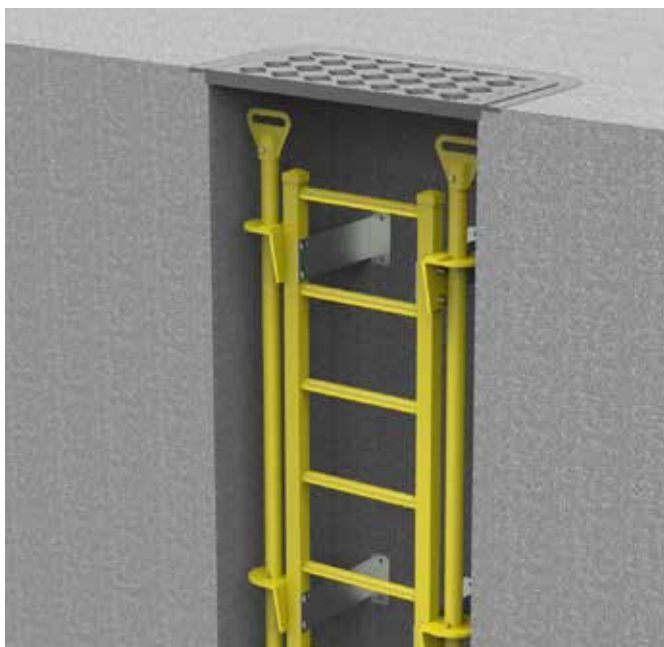

### What are LadderEX® Retract-A-Stiles?

LadderEX® Retract-A-Stiles offer convenience, flexibility, and enhanced safety, especially in confined spaces. Constructed from corrosion-resistant FRP, they require minimal maintenance. Easy to install, they ensure safety at heights with ergonomically designed handles for superior grip and robust fixing brackets for strength and versatility.

LadderEX® components are modular, allowing numerous ladder and access configurations to meet specific site requirements. We can easily integrate your needs into any Retract-A-Stile design.

To comply with AS 1657 standards, ladders must be at least 1700mm long, with stiles extending at least 1000mm above the top landing. The gap between ground level and the first rung should be no less than 90% of the spacing between other rungs.

While Treadwell strives to ensure compliance with AS 1657, bespoke solutions may sometimes result in non-compliant products. In these cases, client approval to proceed is considered consent to supply non-compliant goods or services.

**SAFE-SERIES™**  
Industrial Anti-Slip Solutions

**Anti-Slip Safety Solutions**

SAFE-SERIES™ is Treadwell's selection of pre-manufactured and ready made for installation anti-slip products for harsh environments.

Fabricated from FRP composites, anti-slip decks and rung covers are easy to install over existing stairs to create the toughest and most dependable anti-slip surface available.

Proven in many applications, the series is available in various styles and colours to suit any environment.

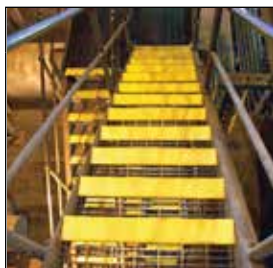

**StairSAFE™**

Long wearing, anti-corrosive, non-slip nosing designed to re-profile the leading edge of any step are the characteristics of StairSAFE™.



**CableSAFE™**

CableSAFE™ creates a safe walkway over exposed pipes, cables, wires and conduit. With a durable anti-slip surface, CableSAFE™ provides a safety bridge for foot traffic over these areas, avoiding slips, trips and falls.



**RungSAFE™**

The abrasive grit surface eliminates the very high possibility of slips from access ladders, avoiding serious ramifications. The surface, while ideal for the negation of slip issues, has been developed so as not to damage bare skin.

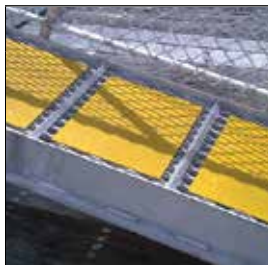

**DeckSAFE™**

DeckSAFE™ is the ultimate solution for slippery ramps, decks, catwalks and landings. Designed to reduce the risk of slips, trips and falls in areas where oil, water and other forms of liquids are present, DeckSAFE™ greatly reduces risks.

**EASY INSTALLATION**

Heavy duty industrial fixings for all applications. Surface for rungs normally applied by using a polyurethane adhesive glue system.



**SAFETY**

Heavy duty grit layer provides an ideal anti-slip surface; likewise, safety yellow offers enhanced visibility.

**OPTIONAL DEPTH AND LENGTH**

Available in four standard depths, 50mm, 75mm, 100mm and 300mm. Custom depths are also available up to 300mm. Available in any length up to 3,250mm.

**CHEMICAL RESISTANT**

Designed to handle most chemicals. Please refer to our Chemical Resistance Guide, found in our SAFE-SERIES™ Product Guide.

**ZERO TRIP RISK**

Smooth bullnose, sloped on an 85° inclined plane ensures no trip risk is posed.

**ROBUST CONSTRUCTION**

Specially formulated resin systems and metallic available on request.

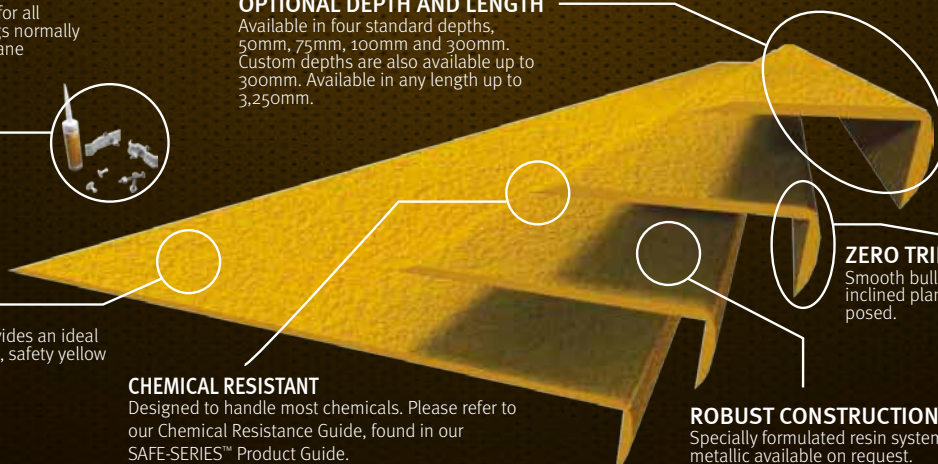

**ArchitEX™**  
Structural Profiles & Structures

**Composite Structural FRP**

The ArchitEX™ range of products comprises of a variety of structural profiles that are manufactured from Fibreglass Reinforced Plastic (FRP). It is through continual research and development that this wide range of fibreglass sections, beams, and profiles are fabricated consistently to ensure satisfactory results even in challenging structural conditions.

The FRP beams, columns and associated sections are produced from high quality FRP material, which makes structures strong as well as rewarding. Durable construction FRP such as fibreglass sections and beams enhances the strength of the entire framework as well as infrastructure. Both fibreglass beams and sections are specifically designed to endure all sorts of environmental inconsistencies.



**Scope of Shapes**

Easy integration to various parts due to the capability to essentially shape any item with a constant cross section which can be pultruded.

**Composite Design Engineering**

A standard shape customised into a pultrusion by modifying the resin or reinforcement to achieve a particular customer need.

**Optimising Resins**

Standard resins can be modified or special resins can be used to maximise performance of the pultrusion in challenging environments, such as those found in high temperature or extremely corrosive areas. Typical resins include polyesters, vinylesters, PVC, epoxies, phenolics, urethanes and blends.

**Choice of Reinforcements**

The type, form, placement and quantity of reinforcements can be customised to optimise economy, develop ascribed strength and create or enhance other physical characteristics of a pultruded part. Typical reinforcements used include glass or carbon fibres in multifilament strands, mat (long fibres held together with a resinous binder) or stitched fabrics.

**Core Materials Options**

Treadwell provides a range of core material options with comprehensive experience in pultruding over various materials including foam, balsa, polyethylene and aluminium.

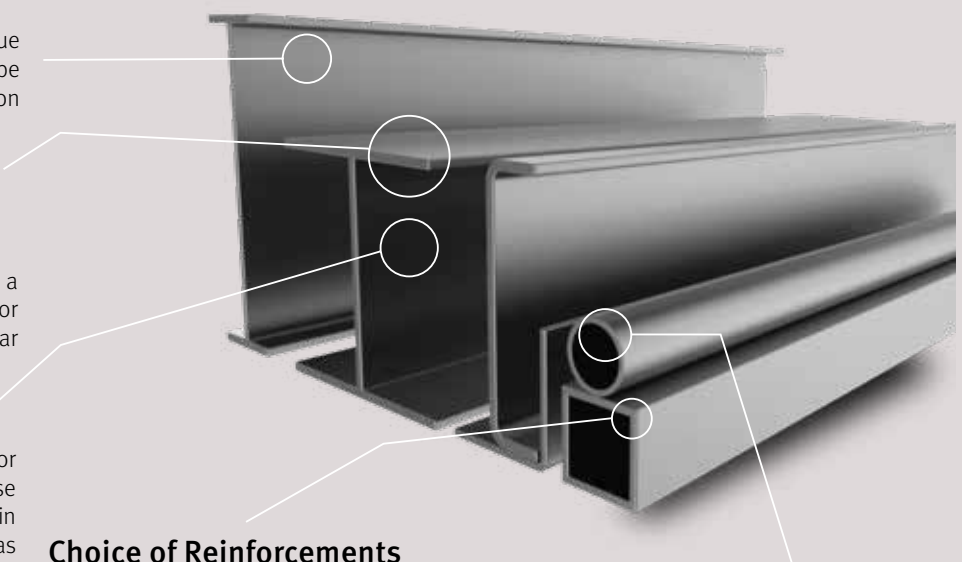













**Structural Design & Analysis**

Our experienced team of engineers and designers can help conceptualise your design and maximise all FRP structural components to offer the most cost effective and simplest solution.



## ArchitEX™ FRP Profiles

ArchitEX™ Range		
C Channel	I-Beam	WF-Beam
		
Double Web Beam	Unequal Leg Angle	Equal Leg Angle
		
Square Hollow Section	Rectangular Hollow Section	Circular Hollow Section
		
Circular Round Bar	Solid Bars	Embedment Angle
		

Please consult our ArchitEX™ Structural Product Guide for more information.



## TreadSLAB® Panel Types Available

### TreadSLAB®

TreadSLAB® is an immensely versatile profile which combines lightweight and inherent strength to provide a durable product with a variety of surface textures and a customisable range of colours. Through the selection of the appropriate resin system, the user can create components that will meet the most demanding of specifications.

Pultruded through a die, TreadSLAB® outperforms with an impressive strength to weight ratio to produce a composite flooring structure that is strong, durable, corrosion resistant and boasts low maintenance on an anti-slip surface.

#### Benefits

- High strength
- Light weight
- Dimensional stability
- Corrosion, chemical, electrical resistance
- Low tooling/installation cost
- Long life
- Favourable performance/lifecycle cost basis versus traditional materials

TreadSLAB® easily outperforms traditional materials in terms of performance/ lifecycle costs.

#### Part: TreadSLAB® Medium Duty Panel

Part Number: **ARX-SL040**

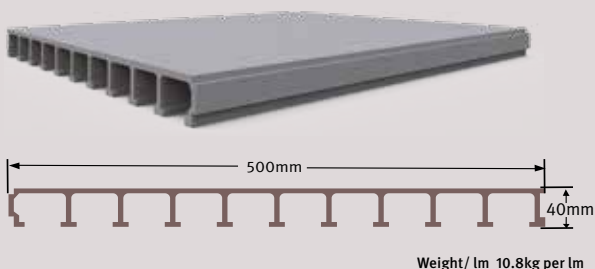

#### Part: TreadSLAB® Heavy Duty Panel

Part Number: **ARX-SL100**

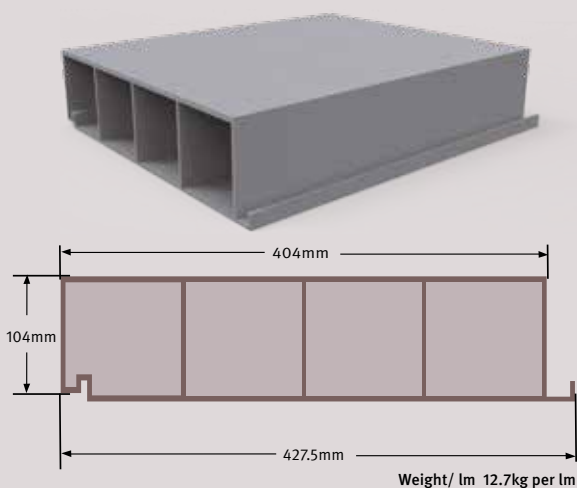

## Case Study – Purlin Replacement



PROJECT INFORMATION	
Project Category:	Structural Infrastructure
Scope of Work:	Supply FRP structural profiles
Treadwell Products:	ArchitEX™ FRP Structural Profiles

Our client represents the world’s largest integrated titanium dioxide project. As a vertically integrated producer of titanium dioxide and inorganic chemicals, this company mines and produces titanium related products, amongst others. Their products add brightness and durability to paints, plastics, paper and other everyday products.

The client needed the purlin replaced in one of their storage facilities. Treadwell was engaged to supply the FRP structural profiles, whilst design and engineer services were provided by an external party.



### Treadwell's Solution:

- 1** ArchitEX™ FRP structural profiles are constructed from premium resin systems which ensure durability with built-in corrosion resistant properties.
- 2** Treadwell’s FRP is naturally non-conductive which provide electrical safety.
- 3** FRP is simply fabricated and modified on site. This means there is no need for any hot works permit.
- 4** Being lightweight and easy to install, FRP is very manageable during construction.
- 5** Given the nature of FRP, any system utilizing it is virtually maintenance free, keeping maintenance costs to a minimum.



# Our Partners





Strathalbyn, South Australia - Factory & Warehouse



### Material Availability

We have established extensive stockholdings in Australia, ready to be fabricated or shipped according to your project requirements. With offices and warehouses located throughout Australia, shipment to site can be quickly arranged.

Our in-house design and engineering teams have exceptional CAD capabilities. Our factory features top of the range automated CNC equipment allowing project requirements to be quickly fulfilled.

Strathalbyn, South Australia - Factory & Warehouse

## Australia

### SOUTH AUSTRALIA

▶ **ADELAIDE (HEAD OFFICE & WAREHOUSE)**

58 DEEDS ROAD  
NORTH PLYMTON, SA 5037

▶ **STRATHALBYN (FACTORY & WAREHOUSE)**

22 DUNREATH ROAD  
STRATHALBYN, SA 5255

### VICTORIA

▶ **MELBOURNE (BRANCH OFFICE & WAREHOUSE)**

37 MACAULAY STREET  
WILLIAMSTOWN, VIC 3016

### NEW SOUTH WALES

▶ **SYDNEY (SERVICED OFFICE)**

SUITE 9, 35-36  
EAST ESPLANADE MANLY, NSW 2095

▶ **WAGGA (BRANCH OFFICE & WAREHOUSE)**

13 CHESHIRE ST,  
WAGGA WAGGA, NSW 2650

### QUEENSLAND

▶ **BRISBANE (SERVICED OFFICE)**

OFFICE 32, 59 ALBANY CREEK ROAD  
ASPLEY, QLD 4034

### WESTERN AUSTRALIA

▶ **PERTH (BRANCH OFFICE & WAREHOUSE)**

UNIT 2, 4 ELMSFIELD ROAD  
MIDVALE, WA 6056

### TASMANIA

▶ **BURNIE (DISTRIBUTION CENTRE)**

28-30 BRICKPORT ROAD  
COOEE, TAS 7320

## New Zealand

### NORTH ISLAND

▶ **PALMERSTON NORTH (OFFICE & WAREHOUSE)**

36 RATANUI STREET AORANGI,  
FEIDLING 4775



**TREADWELL™**

COMPLETE "Fit & Forget" SOLUTIONS