



# Odour Control Cover Product Guide

World leaders in the design and supply of Fibreglass Reinforced Plastic (FRP) Water & Wastewater Product Systems

Treadwell Group is proud to showcase our fibreglass reinforced plastic (FRP) Water & Wastewater Management Solutions Product Guide.

Treadwell’s offerings have evolved with the growth of the company through the years. This latest version brings to you our most comprehensive range of EcoEX™ SureLine® odour control, tank covers and baffle wall solutions to the water and wastewater industries.

Our EcoEX™ range of water & wastewater FRP solutions are designed for use in a multitude of environments where they are continually exposed to corrosion by the elements, chemicals, fumes, submersions, splashes or electrical dangers. In such demanding circumstances, EcoEX™ FRP solutions will outperform many of the standard options in the market.

With sales, design and fabrication facilities strategically located throughout Australia and New Zealand, Treadwell is your one stop shop for FRP solutions. We stock, customise and deliver to ensure that Treadwell is the name you can rely on.

## A BRIEF HISTORY

At Treadwell Group, our core business divisions have been developed utilising the latest FRP technology. We are committed to providing true value to our customers through effective implementation of our comprehensive and diverse range of products and systems.

By continually innovating and having consistent dedication to evolving our offerings, we are competent in delivering unparalleled solutions to a diversified index of industries which are by no means limited to the manufacturing, marine, oil and gas, infrastructure, and food and beverage sectors.

The progression of our products has been focused on ensuring extended design life in varied applications, enabling us to support our continuing commitment to satisfy and add value to our client’s endeavours.



### Treadwell Group Pty Ltd

Australia  
P 1800 246 800  
sales@treadwellgroup.com.au  
treadwellgroup.com.au

New Zealand  
P 0800 244 600  
sales@treadwellgroup.co.nz  
treadwellgroup.co.nz









04	<b>Benefits of FRP</b>
05	<b>Benefits of SureLine® Tank Covers</b>
06	<b>EcoEX™ Overview</b>
07	<b>SureLine® Tank Covers</b>
08	<b>SureLine® Technical Information</b>
10	<b>SureLine® Specification</b>
11	<b>SureLine® MD Technical Information</b>
12	<b>SureLine® MD Specification</b>
13	<b>SureLine® HD Technical Information</b>
16	<b>SureLine® HD Specification</b>
17	<b>SureLine® Hatch Systems</b>
19	<b>SureLine® Access Hatches, Handles &amp; Hinge Systems</b>
20	<b>SureLine® Hatches and Penetrations Specification</b>
21	<b>SureLine® Gaskets and Sealant &amp; Hardware Specification</b>
22	<b>SureLine® FRP Baffle Walls</b>
23	<b>SureLine® FRP Baffle Walls Typical Configurations &amp; Options</b>
24	<b>SureLine® FRP Baffle Walls Specification</b>
25	<b>EcoEX™ FRP Ducting &amp; Stacks</b>
27	<b>Chemical Resistance Guide</b>
32	<b>Case Studies</b>



### Quality Policy

Quality is at the forefront of Treadwell's working practices. With over 15 years of manufacturing to the highest quality standards, Treadwell prides itself on its implementation of strict quality control measures, and strives to supply products that surpass customers' expectations. The company works on a policy of continuous improvement.



### Environmental Policy

Treadwell is conscious of the impact it has on the environment and its associated responsibilities. The company is committed to ensuring its operations satisfy both legal obligations and moral duties. Treadwell has been committed to sustainability for many years and is not just responding to current trends.

**Disclaimer:** The information contained in this Treadwell design guide herein supplied is as a service to our customers and is intended to be used only as a general guide. It is not a substitute for proven engineering practices and designs.

### Benefits of FRP



#### Corrosion, Rust & Rot Proof

Treadwell's superior resin systems offer exceptional resistance to acids, salts and alkalis. At the same time, our FRP systems are rot and termite proof.



#### No Protective Coating Required

Treadwell's unique surface finishing system ensures UV stability in exposed applications, directly eliminating the need for costly surface treatment.



#### Long Term Cost Benefits

Long service life, minimal maintenance costs and low installation costs all combine to provide a very competitive solution over time.



#### Virtually Maintenance Free

Given the nature of FRP, any system utilising it is virtually maintenance free, thus keeping maintenance costs as low as possible.



#### Design Flexibility

The unique capabilities of conforming partial functionality to the use or application, ease to manufacture and to personalise shapes and aesthetics are just some of the key benefits that draw designers, engineers and architects to composite materials.



#### Light Weight, High Strength & Easy Installation

Treadwell's FRP products and systems are lightweight and very manageable. FRP has specific gravity one quarter that of steel and two thirds of aluminium.



#### No Hot Work or Welding Required

FRP is very simply modified or fabricated on site with easy to use hand tools. These can be done without the hassle of first needing to obtain hot work permits.



#### Non-Conductive & RF Transmission Transparent

FRP is transparent to radio frequency transmission and is non-conductive in nature. This makes the material ideal for applications that need to avoid electrical currents and radio frequency.



#### Competitive Vs Traditional Materials

FRP is manufactured from a more economically sound raw material base than metallic alternatives, and is far more structurally sound when compared to timber and plastic materials.



#### Environmentally Sound

Related to the lightweight nature, low need for maintenance and long design life of FRP, the reduced lifecycle cost and environmental footprint are highly sought after characteristics in the modern world. Continual resin formulation fine tuning and development can further raise this environmental profile of composites.

### Treadwell FRP vs Alternative Materials

	FRP	Steel	Aluminum	Timber	Recycled Plastics	Composite Timber
Corrosion Resistance	● ● ● ● ●	●	● ● ● ●	● ●	● ● ● ● ●	● ● ● ● ●
Strength	● ● ● ● ●	● ● ● ● ●	● ● ● ● ●	● ●	● ●	● ●
Lightweight	● ● ● ● ●	●	● ● ● ●	● ● ● ●	● ● ● ●	● ● ● ●
Non-conductivity	● ● ● ● ●	●	● ●	● ● ● ● ●	● ● ● ● ●	● ● ● ● ●
Thermal Expansion	●	● ● ● ● ●	● ● ● ● ●	● ●	● ● ● ●	● ●
Fabrication Ease	● ●	● ● ●	● ● ●	● ● ● ● ●	● ● ● ● ●	● ● ● ● ●
Cost vs Time	● ● ● ● ●	●	● ●	● ●	● ● ●	● ●
Slip Resistance	● ● ● ● ● <sup>1</sup>	● ●	● ●	● ●	● ●	● ●
Fire Rating	● ● ● ● ● <sup>2</sup>	● ● ● ● ●	● ● ● ● ●	● ●	●	● ●

<sup>1</sup> Tested to comply with AS 4586, 2013

<sup>2</sup> Tested to comply with BCA C10.1 and AS1530.3

## Benefits of SureLine® Tank Covers



### Corrosion Resistant



- Manufactured from premium isophthalic and vinyl ester resin systems
- Superior protection against corrosive elements in water and wastewater treatment operations.
- Allows the water to be safe and usable according to AS 4020.



### Cost Savings

- Longer service life, less maintenance, and life cost savings as compared to other materials.
- Allows better and viable components into the associated framework.

### High Strength

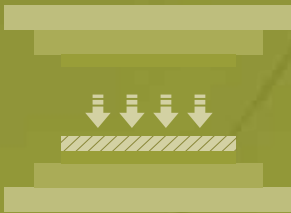

- Manufactured by automated pultrusion process.
- Utilises high glass-fibre content and results in unparalleled product consistency.
- Compression moulding and vacuum moulding processes are used.



### Turn Key Solutions

- Pre-fabricated to eliminate field fabrication and make installation quick and easy.
- Act as an applicable odour control system.
- Solutions include all necessary accessories.



### Durability



- Highly durable.
- Greater resistance to breaks and twists which ensure better longevity.
- Reduce the harmful effects of added tension on the surface and relieving the framework.



### Customised System

- Our experienced technical team customises designs to meet project specific load requirements.



### UV Protection

- Exterior coatings and stabilisers provide UV protection and ensure long service life.

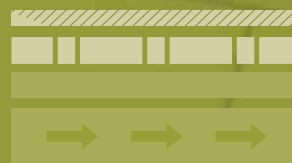

### Low Profile

- SureLine® low profile covers reduce the operating cost and size of scrubber units compared to domes.
- Aesthetically pleasing flat covers.
- Eliminate confined-entry issues.
- Provide protection for equipment located on top of the cover instead of below.



### Light Weight

- Strength-to-weight properties of FRP reduce loads on tank walls and floors.
- Ease cover removability and installation.
- Can be transported anywhere easily and installed seamlessly.

### What is EcoEX™ SureLine® FRP Odour Control Covers

EcoEX™ odour control covers are an engineered solution designed for containing odours, particulate and corrosive gases over tanks and equipment. EcoEX™ offers two odour control panel styles - our SureLine® & SureLine® HD customisable odour control cover systems which are manufactured from premium grade fibreglass resins of your choice or as advised by our engineering assistants. Our customised tank covers contain the odours emitting from the water mass. The volatile organic compounds (VOCs) that cause the foul smells are halted with the SureLine® covers which result in an effective odour control system.

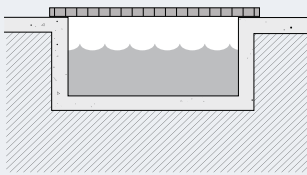

Flat, Clear Span

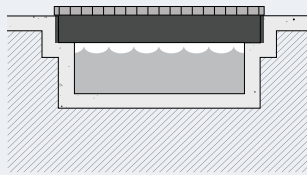

Flat, Beam-supported

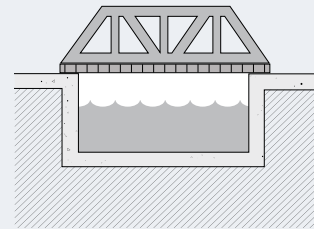

Flat, Truss-supported



*SureLine® & fixed hatches. Victoria, Australia.*



*SureLine® removable pump cover. Victoria, Australia.*



## SureLine® Tank Covers

SureLine® covers are used in many wastewater and sewage treatment applications the globe over.

SureLine® odour control cover systems is a lightweight custom extruded interlocking panel system that can be designed, engineered and fabricated to suit the specifics of your application. SureLine® can be designed as a load-bearing platform solution, enabling operators to safely reach covered areas. The SureLine® system can also be designed as a non-trafficable odour control cover system, meeting AS1170 requirements. SureLine® is a lighter solution to that of its stronger counterpart, SureLine® HD, and is ideal for lighter smaller span tanks.

SureLine® odour control cover systems also offer a range of inspection hatches, maintenance hatches and full access hatches with safety grates installed. Covers can be manufactured in whole sections or available as an option in certain sizes to suit specific requirements. SureLine® covers may be designed to incorporate take off points and access where required.

SureLine® covers are sealed systems designed to contain odours and/or operate in conjunction with scrubber systems that draw the trapped gases off and treat them to eliminate odour, offering a 99.9% capture rate.

Our offerings for SureLine® come in the form of:

- SureLine®
- SureLine® MD
- SureLine® HD

## Applications

Inlet Works & Grit Covers	Chlorine Contact Basins
Clarifiers	Filtrate Storage Tanks
Aeration & Equalisation	Chemical Process Tanks
Sedimentation	Balance Tanks
Sludge & Gravity Thickeners	



*SureLine® & various hatch types. Queensland, Australia.*

SureLine®

SureLine® covers are light weight, low profile odour control covers designed for smaller inlet works and provide a range of other applications. EcoEX™ SureLine® systems are easy to install and extremely lightweight with easy to add additional penetrations onsite. SureLine® tank cover systems are ideal for channels, odd-shaped basins, or covers with numerous penetrations where VOC's are present. SureLine® system components include SureLine® FRP panels, FRP beams, access hatches and stainless steel hardware.

Part: SureLine® Standard Panel

Part Number: ARX-SL054

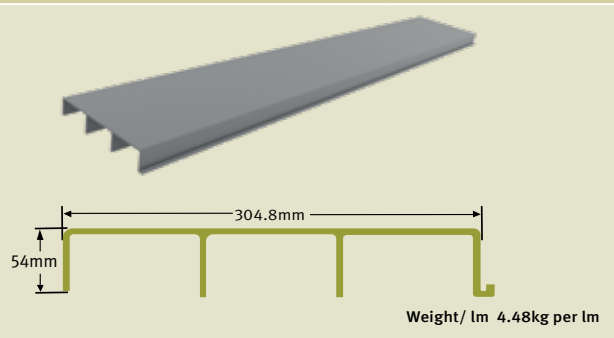

$A_w$	1036 mm <sup>2</sup>	$W_t$	4.48 kg/m
$I$	765865mm <sup>4</sup>	$S$	14798 mm <sup>3</sup>

Span (mm)	Maximum Load (kPa)	Deflection (kPa)									
		L/D=120	L/D=150	L/D=180	L/D=220	L/D=250	L/D=300	L/D=350	L/D=400	L/D=500	
400	99.98									80.79	
600	44.44							38.27	33.49	26.79	
800	25.00					23.59	19.66	16.85	14.74	11.79	
1000	16.00				14.00	12.32	10.27	8.80	7.70	6.16	
1200	11.11			10.02	8.20	7.21	6.01	5.15	4.51	3.61	
1400	8.16		7.62	6.35	5.20	4.57	3.81	3.27	2.86	2.29	
1600	6.25		5.13	4.27	3.50	3.08	2.56	2.20	1.92	1.54	
1800	4.94	4.52	3.61	3.01	2.46	2.17	1.81	1.55	1.35	1.08	
2000	4.00	3.30	2.64	2.20	1.80	1.58	1.32	1.13	0.99	0.79	
2200	3.31	2.48	1.99	1.66	1.35	1.19	0.99	0.85	0.74	0.60	
2400	2.78	1.92	1.53	1.28	1.04	0.92	0.77	0.66	0.57	0.46	
2600	2.37	1.51	1.21	1.01	0.82	0.72	0.60	0.52	0.45	0.36	
2800	2.04	1.21	0.97	0.81	0.66	0.58	0.48	0.41	0.36	0.29	
3000	1.78	0.98	0.79	0.66	0.54	0.47	0.39	0.34	0.29	0.24	
3200	1.56	0.81	0.65	0.54	0.44	0.39	0.32	0.28	0.24	0.19	

Installation

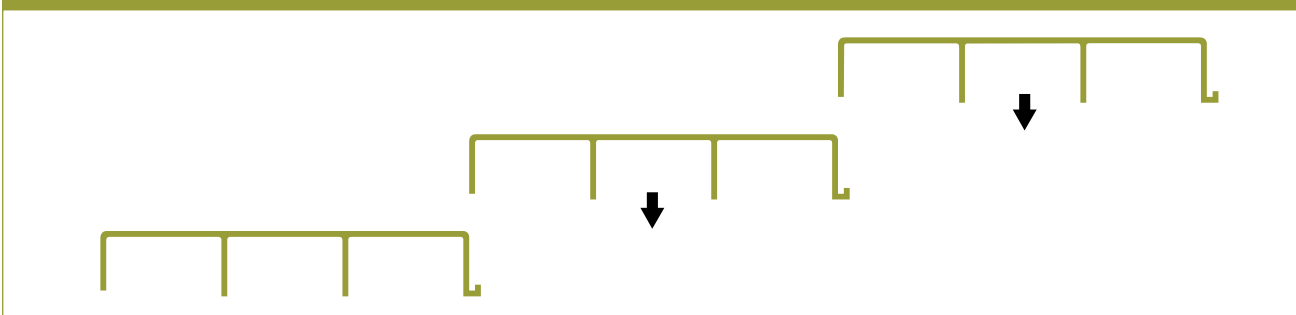



Typical Detail

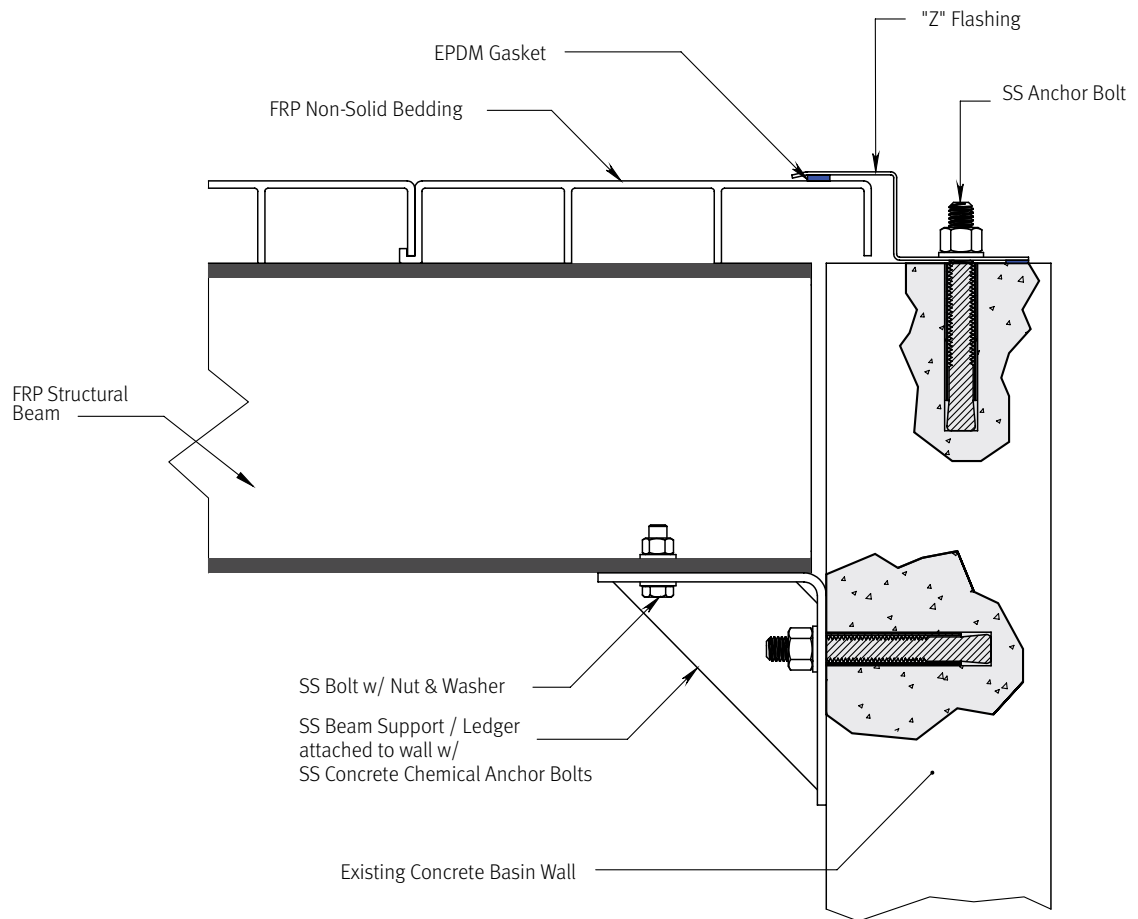

BEAM SUPPORTED CONNECTION



SureLine® with raised hatches. Victoria, Australia.

**General**

**1.0 Scope**

- 1.1 Scope of work shall include materials for fibreglass reinforced plastic (FRP) odour control covers including: EcoEX™ SureLine® odour control cover deck panels; ArchitEX™ FRP structural supports, EcoEX™ SureLine® flashing and trim, fasteners and anchors, EcoEX™ SureLine® gaskets.
- 1.2 SureLine® odour control covers shall be designed by Treadwell to be practicably odour secure unless specified otherwise.

**2.0 Standards/ Related Documents**

- 2.1 The odour control covers shall adhere to the applicable sections of:
  - 2.1.1 ASTM E84 Surface Burning Characteristics Of Building Materials
  - 2.1.2 ASTM D638 Standard Test Method For Tensile Properties Of Plastics
  - 2.1.3 ASTM D695 Standard Test Method For Compressive Properties Of Plastics
  - 2.1.4 ASTM D790 Standard Test Method For Flexural Properties Of Plastics
  - 2.1.5 AS 1170 Structural Design Actions

**3.0 Design Criteria**

- 3.1 Design Loads
  - 3.1.1 Wind Uplift \_\_\_\_\_ kPa
  - 3.1.2 Dead Load \_\_\_\_\_ kPa
  - 3.1.3 Live Loads \_\_\_\_\_ kPa
- 3.2 Cover Panel Removability
  - 3.2.1 Each SureLine® odour control cover panel shall be removable without having to remove no more than its two adjacent panels.
  - 3.2.2 Each SureLine® odour control cover panel shall be removable vertically and without cutting of a cover component.

**4.0 Submittals**

- 4.1 Shop drawings shall be submitted by Treadwell (unless provided by the client) displaying clearly material sizes, types, styles, product codes and including types and sizes of fasteners as well as a layout if required.
- 4.2 Technical data and sample pieces can also be submitted if required.

**5.0 Quality Assurance**

Quality surrounds every aspect of Treadwell’s commitment to our superior products and efficiency. Treadwell’s quality assurance strictly adheres to the high quality control standards placed to conform to relevant specifications, codes, Australian Standards and contractual requirements in a timely manner.

**6.0 Materials**

- 6.1 SureLine® Odour Control Covers shall have top surface thickness of 4.76mm (min). Deck leg supports shall be 6.35mm thick.
- 6.2 Resins shall be selected from Treadwell’s EX-Series® range of resins with chemical formulations as necessary to provide the corrosion resistance, strength and any other physical properties as required.
- 6.3 Glass fibre reinforcements shall be a minimum of half of the material weight.
- 6.4 Materials shall be fire retardant and have a flame spread rating of 25 or less per ASTM E84.
- 6.5 Materials shall exhibit these physical properties (at a minimum):

Tensile Strength	206.8 MPa	ASTM D638
Compressive Strength	206.8 MPa	ASTM D695
Flexural Strength	206.8 MPa	ASTM D790

- 6.6 The top of the tank cover decking shall be flat and non-profiled with a factory applied, anti-slip, UV resistant surface. Typical colour of EcoEX™ SureLine® is grey unless specified with RAL code.

**7.0 Acceptable Manufacturer**

SureLine® odour control covers shall be manufactured by Treadwell Group Pty Ltd of Australia, EcoEX™ division.



## SureLine® MD Technical Information

### SureLine® MD

SureLine® MD is an immensely versatile profile which combines lightweight and inherent strength to provide a durable product typically provided with an anti-slip surface and in customisable range of colours to suit the specifics of your application. SureLine® MD is designed to withstand loads to enable operators to safely reach covered areas as well as a non-trafficable odour control cover system.

MD or Medium Duty constructions make this cover a flexible intermediate alternative to meet the intermediate loading requirements.

SureLine® MD outperforms with an impressive strength to weight ratio to produce a composite cover that is strong, durable, corrosion resistant and boasts extremely low maintenance.

#### Part: SureLine® Medium Duty Panel

Part Number: **ARX-SL040**

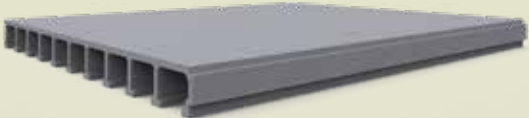
	$A_w$	2200 mm <sup>2</sup>	$W_t$	10.8 kg/m
	$I$	1021011 mm <sup>4</sup>	$S$	39930 mm <sup>3</sup>

500mm  
40mm  
Weight/ lm 10.8kg per lm

Span (mm)	Maximum Load (kPa)	Deflection (kPa)									
		L/D=100	L/D=120	L/D=150	L/D=180	L/D=220	L/D=250	L/D=300	L/D=350	L/D=400	L/D=500
400	226.60					196.78	173.17	144.31	123.69	108.23	86.59
600	122.33	140.68	117.23	93.78	78.15	63.94	56.27	46.89	40.19	35.17	28.14
800	68.81	61.43	51.19	40.95	34.13	27.92	24.57	20.48	17.55	15.36	12.29
1000	44.04	31.97	26.64	21.31	17.76	14.53	12.79	10.66	9.13	7.99	6.39
1200	30.58	18.67	15.56	12.45	10.37	8.49	7.47	6.22	5.33	4.67	3.73
1400	22.47	11.82	9.85	7.88	6.57	5.37	4.73	3.94	3.38	2.96	2.36
1600	17.20	7.95	6.62	5.30	4.41	3.61	3.18	2.65	2.27	1.99	1.59
1800	13.59	5.59	4.66	3.73	3.11	2.54	2.24	1.86	1.60	1.40	1.12
2000	11.01	4.09	3.40	2.72	2.27	1.86	1.63	1.36	1.17	1.02	0.82
2200	9.10	3.07	2.56	2.05	1.71	1.40	1.23	1.02	0.88	0.77	0.61
2400	7.65	2.37	1.97	1.58	1.32	1.08	0.95	0.79	0.68	0.59	0.47
2600	6.51	1.87	1.55	1.24	1.04	0.85	0.75	0.62	0.53	0.47	0.37
2800	5.62	1.49	1.25	1.00	0.83	0.68	0.60	0.50	0.43	0.37	0.30
3000	4.89	1.22	1.01	0.81	0.68	0.55	0.49	0.41	0.35	0.30	0.24
3200	4.30	1.00	0.84	0.67	0.56	0.46	0.40	0.33	0.29	0.25	0.20

### Installation



## General

### 1.0 Scope

- 1.1 Scope of work shall include materials for fibreglass reinforced plastic (FRP) odour control covers including: EcoEX™ SureLine® odour control cover deck panels; ArchiEX™ FRP structural supports, EcoEX™ SureLine® flashing and trim, fasteners and anchors, EcoEX™ SureLine® gaskets.
- 1.2 SureLine® odour control covers shall be designed by Treadwell to be practicably odour secure unless specified otherwise.

### 2.0 Standards/ Related Documents

- 2.1 The odour control covers shall adhere to the applicable sections of:
  - 2.1.1 ASTM E84 Surface Burning Characteristics Of Building Materials
  - 2.1.2 ASTM D638 Standard Test Method For Tensile Properties Of Plastics
  - 2.1.3 ASTM D695 Standard Test Method For Compressive Properties Of Plastics
  - 2.1.4 ASTM D790 Standard Test Method For Flexural Properties Of Plastics
  - 2.1.5 AS 1170 Structural Design Actions

### 3.0 Design Criteria

- 3.1 Design Loads
  - 3.1.1 Wind Uplift \_\_\_\_\_ kPa
  - 3.1.2 Dead Load \_\_\_\_\_ kPa
  - 3.1.3 Live Loads \_\_\_\_\_ kPa
- 3.2 Cover Panel Removability
  - 3.2.1 Each SureLine® odour control cover panel shall be removable without having to remove no more than its two adjacent panels.
  - 3.2.2 Each SureLine® odour control cover panel shall be removable vertically and without cutting of a cover component.

### 4.0 Submittals

- 4.1 Shop drawings shall be submitted by Treadwell (unless provided by the client) displaying clearly material sizes, types, styles, product codes and including types and sizes of fasteners as well as a layout if required.
- 4.2 Technical data and sample pieces can also be submitted if required.

### 5.0 Quality Assurance

Quality surrounds every aspect of Treadwell's commitment to our superior products and efficiency. Treadwell's quality assurance strictly adheres to the high quality control standards placed to conform to relevant specifications, codes, Australian Standards and contractual requirements in a timely manner.

## Products

### 6.0 Materials

- 6.1 All FRP structural components including decking, beams, and framing shall be manufactured the ArchiEX™ range.
- 6.2 Glass fibre reinforcements shall be minimum 50% of the material weight.
- 6.3 Materials shall be fire retardant with flame spread rating of 25 or less per ASTM E84.
- 6.4 Materials shall exhibit these physical properties (minimum):

Tensile Strength	206.8 MPa	ASTM D638
Compressive Strength	206.8 MPa	ASTM D695
Flexural Strength	206.8 MPa	ASTM D790
Tensile Modulus	20.6 GPa	ASTM D638
Izod Impact (Notched)	1.1 J/mm	ASTM D256
Water Absorption	0.2%	ASTM D570

### 6.5 SureLine® MD Odour Control Covers

- 6.5.1 Resins shall be selected from Treadwell's EX-Series® range of resins with chemical formulations as necessary to provide the corrosion resistance, strength and any other physical properties as required.
- 6.5.2 Deck panels shall be sealed at side-laps with factory installed, non adhesive, 25.4mm diameter neoprene bulb gasket.
- 6.5.3 Top of SureLine® MD odour control cover decking shall be flat and have an anti-slip, UV resistant surface.
- 6.5.4 Typical colour of EcoEX™ SureLine® MD is grey unless specified with RAL code.

### 7.0 Acceptable Manufacturer

SureLine® odour control covers shall be manufactured by Treadwell Group Pty Ltd of Australia, EcoEX™ division.



# SureLine® HD Technical Information

## SureLine® HD

The SureLine® odour control tank cover system is comprised of an FRP interlocking panel system that can be designed, engineered and fabricated to suit the specifics of your application. SureLine® HD can be designed as a load-bearing platform solution enabling operators to safely reach covered areas. The Sureline® HD system can also be designed as a non-trafficable odour control cover system, meeting AS1170 requirements.

HD or Heavy-duty constructions means that the cover can accommodate various loading requirements and meet a broad range of local and environmental requirements. Handrails can be accommodated if required and mounted directly off the cover.

SureLine® HD odour control cover systems also offer a range of inspection hatches, maintenance hatches and full access hatches with safety grates or grilles installed.

SureLine® HD are sealed systems designed to contain odours and/or operate in conjunction with scrubber systems that draw the trapped gases off and treat them to eliminate odour.

### Part: SureLine® Heavy Duty Panel

Part Number: **ARX-SL100**

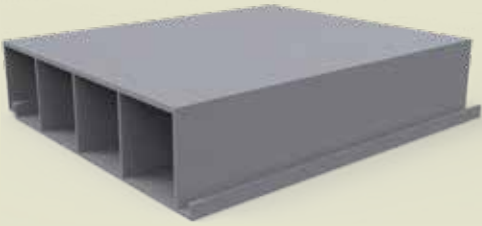
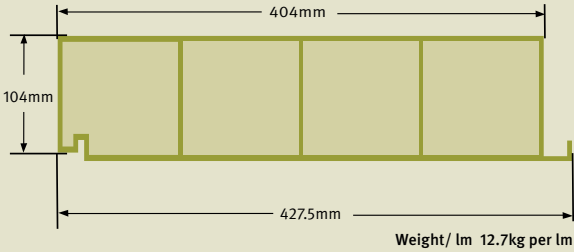
$A_w$	2080 mm <sup>2</sup>	$W_t$	12.7 kg/m
$I$	11096613 mm <sup>4</sup>	$S$	192449 mm <sup>3</sup>

Span (mm)	Maximum Load (kPa)	Deflection (kPa)									
		L/D=100	L/D=120	L/D=150	L/D=180	L/D=220	L/D=250	L/D=300	L/D=350	L/D=400	L/D=500
1000	106.06							105.70	90.60	79.28	63.42
1200	88.38						79.43	66.19	56.74	49.65	39.72
1400	75.76				73.09	59.80	52.63	43.86	37.59	32.89	26.31
1600	66.29			60.82	50.68	41.47	36.49	30.41	26.06	22.81	18.25
1800	58.92		54.71	43.76	36.47	29.84	26.26	21.88	18.76	16.41	13.13
2000	53.03	48.71	40.59	32.47	27.06	22.14	19.48	16.24	13.92	12.18	9.74
2200	48.21	37.09	30.91	24.73	20.61	16.86	14.84	12.36	10.60	9.27	7.42
2400	44.19	28.86	24.05	19.24	16.04	13.12	11.55	9.62	8.25	7.22	5.77
2600	38.86	22.89	19.07	15.26	12.71	10.40	9.15	7.63	6.54	5.72	4.58
2800	33.51	18.44	15.37	12.29	10.25	8.38	7.38	6.15	5.27	4.61	3.69
3000	29.19	15.07	12.56	10.05	8.37	6.85	6.03	5.02	4.31	3.77	3.01
3200	25.65	12.47	10.39	8.32	6.93	5.67	4.99	4.16	3.56	3.12	2.49
3400	22.72	10.44	8.70	6.96	5.80	4.74	4.17	3.48	2.98	2.61	2.09
3600	20.27	8.82	7.35	5.88	4.90	4.01	3.53	2.94	2.52	2.20	1.76
3800	18.19	7.52	6.26	5.01	4.18	3.42	3.01	2.51	2.15	1.88	1.50
4000	16.42	6.46	5.38	4.31	3.59	2.94	2.58	2.15	1.85	1.61	1.29
4200	14.89	5.59	4.66	3.73	3.11	2.54	2.24	1.86	1.60	1.40	1.12
4400	13.57	4.87	4.06	3.25	2.71	2.21	1.95	1.62	1.39	1.22	0.97
4600	12.41	4.27	3.56	2.85	2.37	1.94	1.71	1.42	1.22	1.07	0.85

### Installation

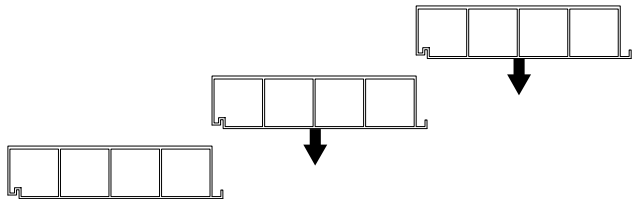

### Unique Panel Removal Feature

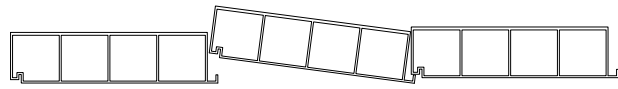

This allows access to a central panel without having to remove all panels.

### Applications

Headworks & Grit Covers	Sludge & Gravity Thickeners
Clarifiers	Chlorine Contact Basins
Aeration & Equalization	Filtrate Storage Tanks
Sedimentation	Chemical Process Tanks

Anti-slip surfaces for all SureLine® meet AS4586 requirements for slip resistance.

All SureLine® profiles can be colour matched with any RAL code.

### Load Span Table

Maximum Allowable Load - Safety Factor = 2.5

Span(m)	Uniform Live Load (kPa)	Concentrated Load (kg)
	L/D = 120	L/D = 180
6.10m	1.00	140
5.50m	1.50	173
4.90m	2.25	217
4.30m	3.50	282
3.70m	5.75	375

### Typical Details

#### Concrete Wall

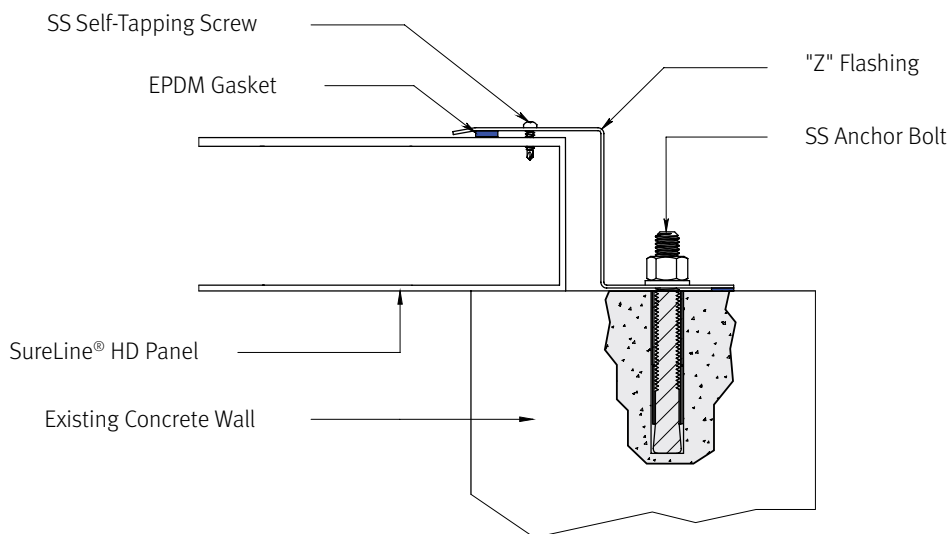

CLEAR SPAN CONNECTION



Concentrated load distributed over 300mm x 600mm area.

**Beam Supported Connection**

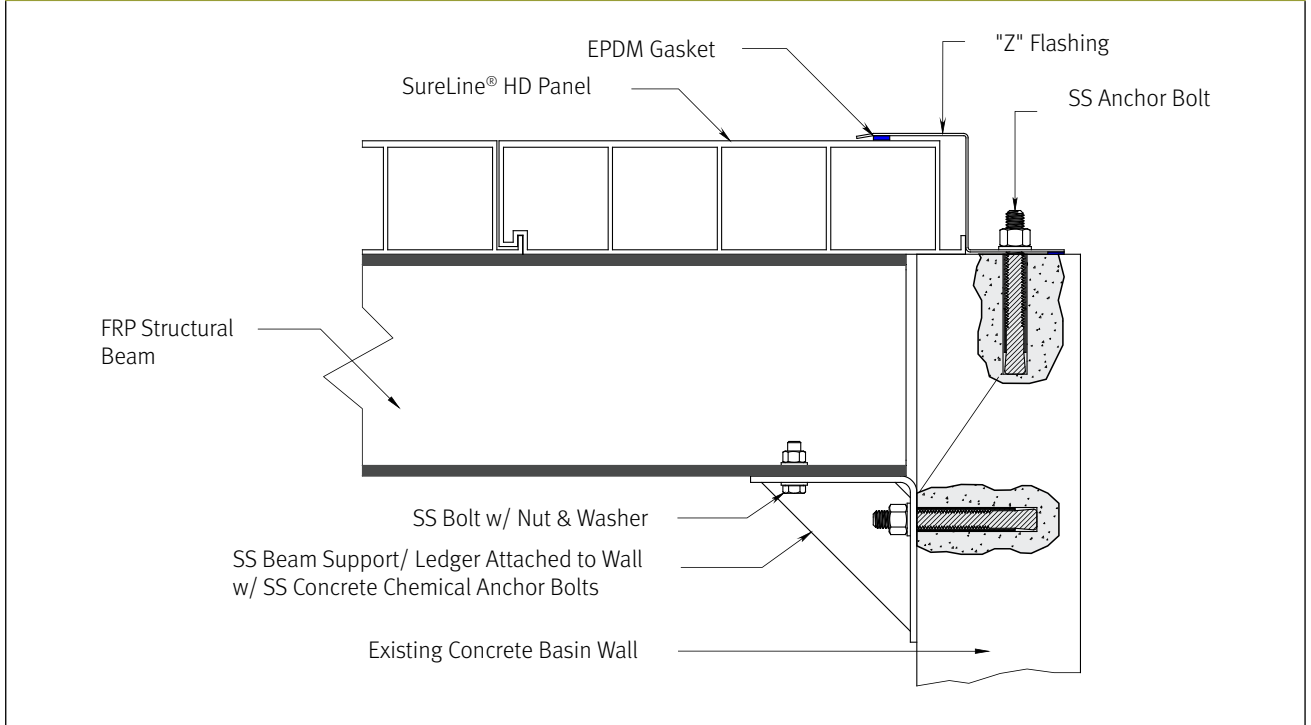

Concentrated load distributed over 300mm x 600mm area.

**Flush Concrete Wall**

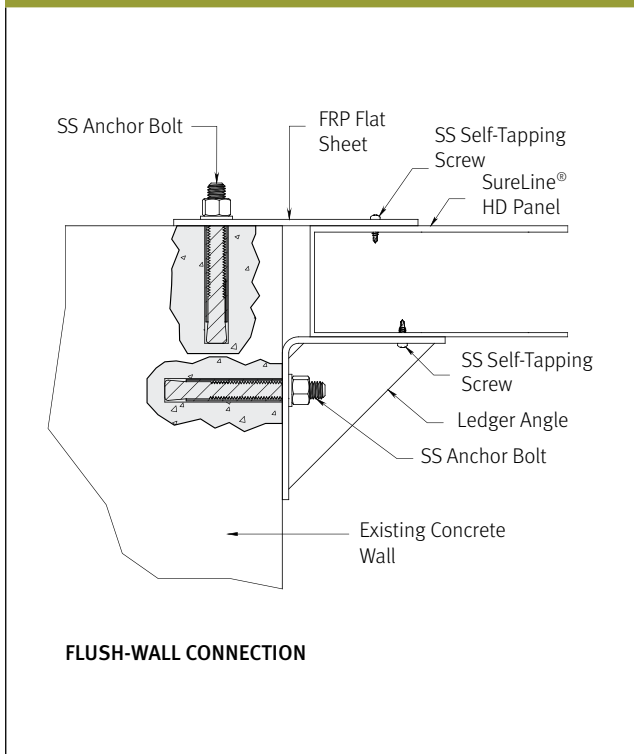

**Flush Concrete Wall**

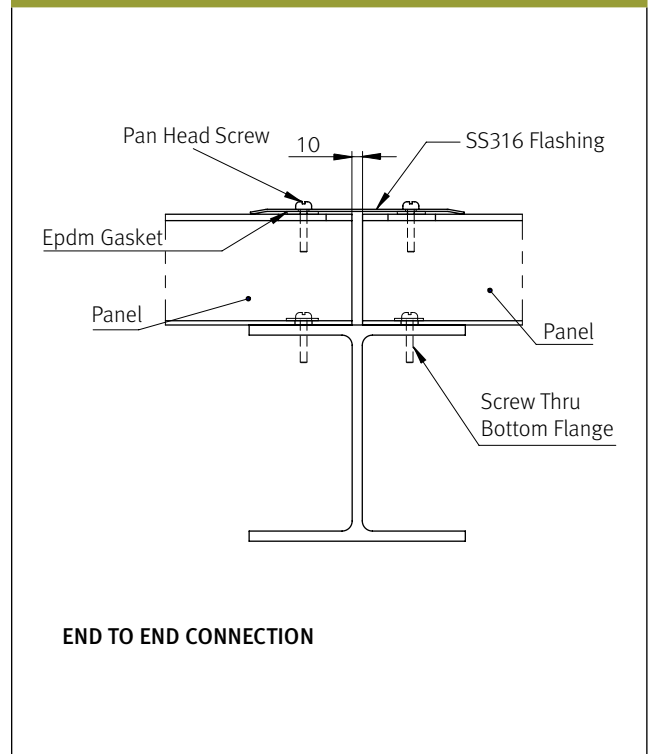

**General**

**1.0 Scope**

- 1.1 Scope of work shall include materials for fibreglass reinforced plastic (FRP) odour control covers including EcoEX™ SureLine® HD odour control cover deck panels, ArchitEX™ FRP structural supports, EcoEX™ SureLine® HD flashing and trim, fasteners and anchors, EcoEX™ SureLine® HD gaskets.
- 1.2 SureLine® HD odour control covers shall be designed by Treadwell to be practicably odour secure unless specified otherwise.

**2.0 Standards/ Related Documents**

- 2.1 The odour control covers shall adhere to the applicable sections of:
  - 2.1.1 ASTM E84 Surface Burning Characteristics Of Building Materials
  - 2.1.2 ASTM D256 Standard Test Method For Determining Izod Impact
  - 2.1.3 ASTM D570 Standard Test Method For Water Absorption Of Plastics
  - 2.1.4 ASTM D638 Standard Test Method For Tensile Properties Of Plastics
  - 2.1.5 ASTM D695 Standard Test Method For Compressive Properties Of Plastics
  - 2.1.6 ASTM D790 Standard Test Method For Flexural Properties Of Plastics
  - 2.1.7 AS 1170 Structural Design Actions

**3.0 Design Criteria**

- 3.1 Design Loads
  - 3.1.1 Wind Uplift \_\_\_\_\_ kPa
  - 3.1.2 Dead Load \_\_\_\_\_ kPa
  - 3.1.3 Live Load \_\_\_\_\_ kPa
- 3.2 Cover Panel Removability
  - 3.2.1 Each SureLine® HD odour control cover panel shall be removable without having to remove no more than its two adjacent panels.
  - 3.2.2 Each SureLine® HD odour control cover panel shall be removable vertically and without cutting of a cover component.

**4.0 Submittals**

- 4.1 Shop drawings shall be submitted by Treadwell (unless provided by the client) displaying clearly material sizes, types, styles, product codes and including types and sizes of fasteners as well as a layout if required.
- 4.2 Technical data and sample pieces can also be submitted if required.

**5.0 Quality Assurance**

Quality surrounds every aspect of Treadwell’s commitment to our superior products and efficiency. Treadwell’s quality assurance strictly adheres to the high quality control standards placed to conform to relevant specifications, codes, Australian Standards and contractual requirements in a timely manner.

**Products**

**6.0 Materials**

- 6.1 All FRP structural components including decking, beams, and framing shall be manufactured the ArchitEX™ range.
- 6.2 Glass fibre reinforcements shall be minimum 50% of the material weight.
- 6.3 Materials shall be fire retardant with flame spread rating of 25 or less per ASTM E84.
- 6.4 Materials shall exhibit these physical properties (minimum):

Tensile Strength	206.8 MPa	ASTM D638
Compressive Strength	206.8 MPa	ASTM D695
Flexural Strength	206.8 MPa	ASTM D790
Tensile Modulus	20.6 GPa	ASTM D638
Izod Impact (Notched)	1.1 J/mm	ASTM D256
Water Absorption	0.2%	ASTM D570

- 6.5 SureLine® HD Odour Control Covers
  - 6.5.1 Resins shall be selected from Treadwell’s EX-Series® range of resins with chemical formulations as necessary to provide the corrosion resistance, strength and any other physical properties as required.
  - 6.5.2 Deck panels shall be sealed at side-laps with factory installed, non adhesive, 25.4mm diameter neoprene bulb gasket.
  - 6.5.3 Top of SureLine® HD odour control cover decking shall be flat and have an anti-slip, UV resistant surface.
  - 6.5.4 Typical colour of EcoEX™ SureLine® HD is grey unless specified with RAL code.

**7.0 Acceptable Manufacturer**

SureLine® HD odour control covers shall be manufactured by Treadwell Group Pty Ltd of Australia, EcoEX™ division.

SureLine® Standard FRP Hatch

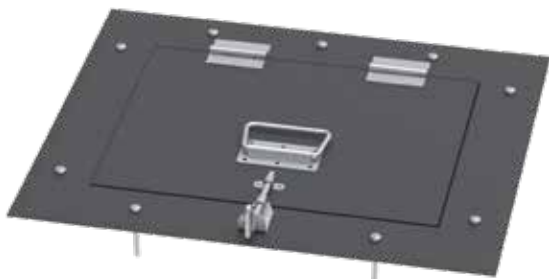
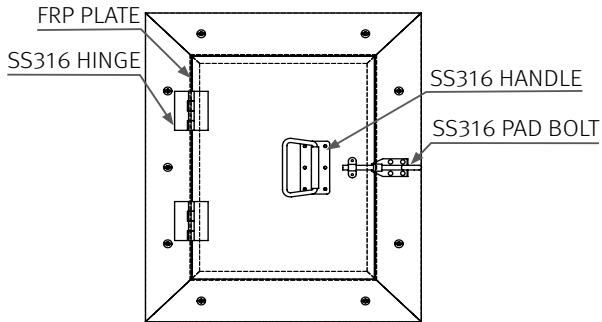

Closed View

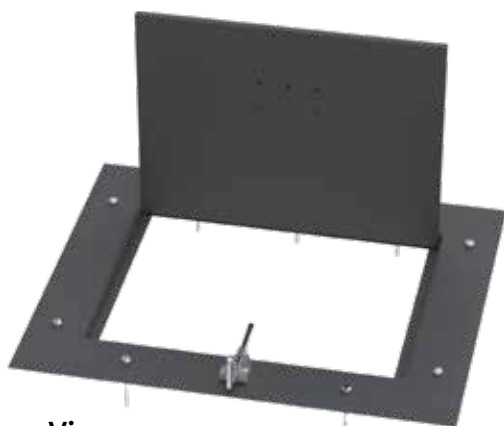

Open View

SureLine® FRP Hatch & Safety Grate

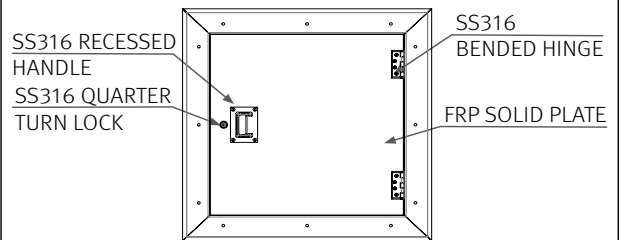

Closed View



Open View



SureLine® FRP Manual Screen Hatch

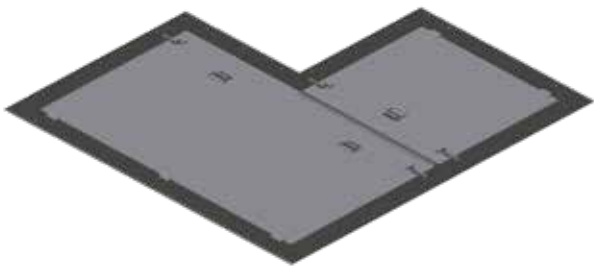
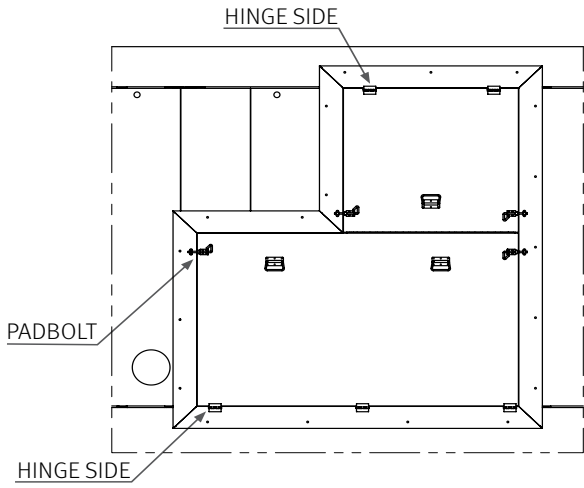

Closed View

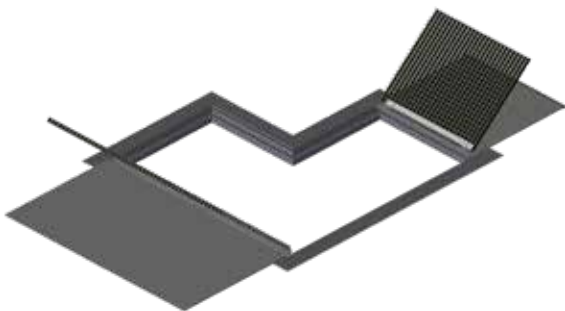

Open View

SureLine® FRP Removable Pump Cover

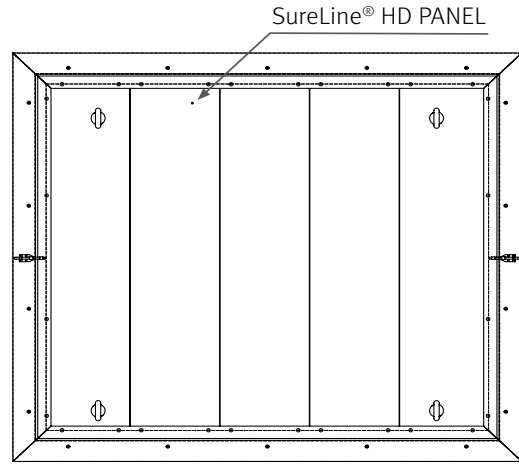

Closed View



Open View

# SureLine® Access Hatches, Handles & Hinge Systems

## SureLine® Access Hatches, Handles & Hinge Systems

Treadwell can custom design any type of cover or hatch using GratEX® Solid Surface Mesh and can simply and effectively make these lockable, removable and even hinged through the use of standard and custom ancillary products such as handles, hinges, frames and cam locks.

If you should have a unique application, please feel free to contact us – there is a good chance we've encountered something similar in the past.

### EX-Series® Non-Metallic Hinge

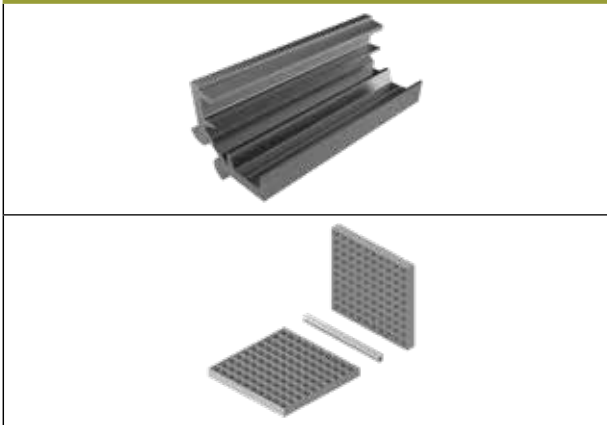

### EX-Series® Non-Metallic Recessed Hinge

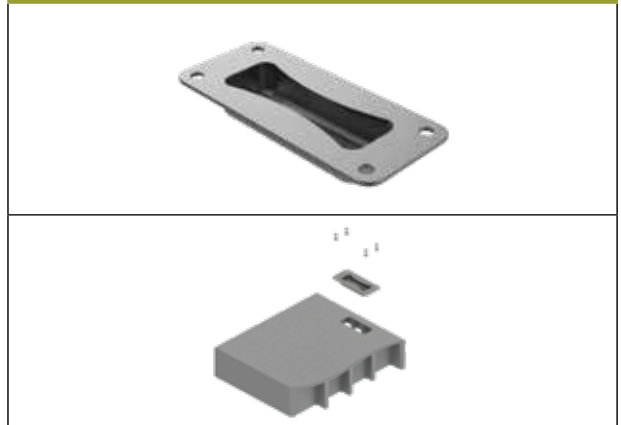

### EX-Series® Spring Loaded Handle



### EX-Series® Eyelet Lift Kit

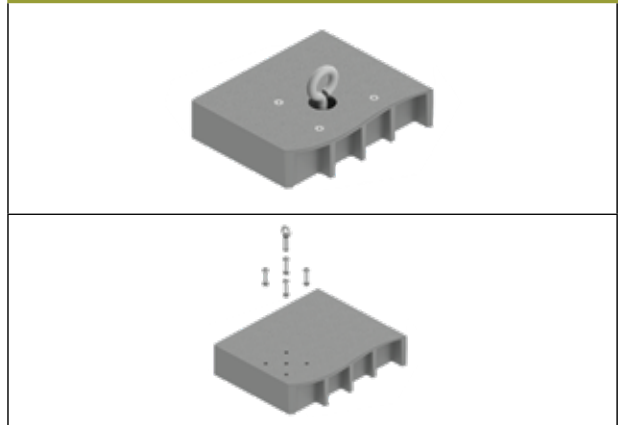

### EX-Series® T-Bar Handle/Keyhole Lift Kit

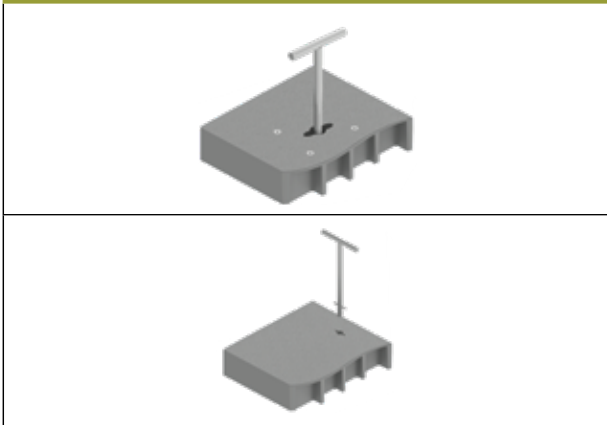

### EX-Series® Lockable Handle

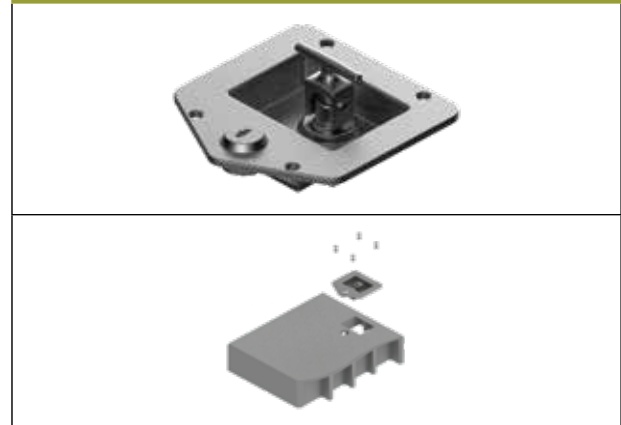

# SureLine® Hatches and Penetrations Specification

## General

### 1.0 Scope

- 1.1 Scope of work shall include materials for hatches, air vents and penetrations including all fibreglass material, stainless steel fasteners, flashings and anchors, and EcoEX™ SureLine® gaskets.
- 1.2 Hatches, air vents and penetrations are to be manufactured as per drawing supplied.

### 2.0 Design Criteria

- 2.1 Hatches and covers with a 136.1kg load spread over the top of the hatch shall be made available for traffic accessibility.

### 3.0 Design Criteria

- 3.1 Shop drawings shall be submitted by Treadwell (unless provided by the client) displaying clearly material sizes, types, styles, product codes and including types and sizes of fasteners as well as a layout if required.
- 3.2 Technical data and sample pieces can also be submitted if required.

### 4.0 Quality Assurance

Quality surrounds every aspect of Treadwell's commitment to our superior products and efficiency. Treadwell's quality assurance strictly adheres to the high quality control standards placed to conform to relevant specifications, codes, Australian Standards and contractual requirements in a timely manner.

## Products

### 5.0 Hatches

- 5.1 Hatches shall have a stainless steel hold-open device and hand-operable latch. Lids shall have an anti-slip and UV resistant surface, with a plastic or stainless steel lift handle installed.

- 5.2 Hatches shall be raised with one-leaf hatch door and fabricated from ArchiEX™ pultruded fibreglass components.
- 5.3 Access hatches shall be sized to fit inside a single deck panel so that a panel with a hatch can be removed without affecting adjacent panels.
- 5.4 Underside of hatch lid shall be sealed with factory installed, 9.53mm diameter neoprene bulb gasket. Perimeter hatch curb shall be sealed to decking surface with sealant.
- 5.5 View port hatches shall be 145mmx250mm or less.

### 6.0 Air Vents

- 6.1 Gooseneck ventilation piping shall be FRP with blind flange extending 152.4mm (min) from top of tank cover.
- 6.2 Stub-vent connections shall be FRP with blind flange extending 152.4mm (min) from top of the tank cover.

### 7.0 Pipe Penetrations

- 7.1 Existing or new pipe penetrations shall be retro fited by Contractor to penetrate cover at a 90-degree angle.
- 7.2 Pipe penetrations shall be flashed in the field with retrofit profiles, zipper type, pipe flashing or equal.

### 8.0 Acceptable Manufacturer

Hatches, air vents and penetrations shall be manufactured/ supplied by Treadwell Group Pty Ltd of Australia, EcoEX™ division.



*SureLine® Odour Cover Hatch. Queensland, Australia.*



# SureLine® Gaskets and Sealant & Hardware Specification

## Gaskets and Sealant

### General

#### 1.0 Scope

1.1 Scope of work for gaskets and sealants.

#### 2.0 Submittals

2.1 Shop drawings shall be submitted by Treadwell (unless provided by the client) displaying clearly material sizes, types, styles, product codes and including types and sizes of fasteners as well as a layout if required.

2.2 Technical data and sample pieces can also be submitted if required.

#### 3.0 Quality Assurance

Quality surrounds every aspect of Treadwell's commitment to our superior products and efficiency. Treadwell's quality assurance strictly adheres to the high quality control standards placed to conform to relevant specifications, codes, Australian Standards and contractual requirements in a timely manner.

#### 4.0 Submittals

4.1 All pane side laps and perimeter conditions shall be gasketed.

4.2 Foam EPDM or neoprene gaskets shall be installed underneath all odour control covers and flashings.

#### 5.0 Acceptable Manufacturer

All gaskets and sealants to be supplied by Treadwell Group Pty Ltd of Australia, EcoEX™ division.

## Hardware Specification

### General

#### 6.0 Scope

6.1 Scope of work for hardware.

#### 7.0 Submittals

7.1 Shop drawings shall be submitted by Treadwell (unless provided by the client) displaying clearly material sizes, types, styles, product codes and including types and sizes of fasteners as well as a layout if required.

7.2 Technical data and sample pieces can also be submitted if required.

#### 8.0 Quality Assurance

Quality surrounds every aspect of Treadwell's commitment to our superior products and efficiency. Treadwell's quality assurance strictly adheres to the high quality control standards placed to conform to relevant specifications, codes, Australian Standards and contractual requirements in a timely manner.

#### 9.0 Hardware

9.1 Fasteners, anchors, hinges, and other structural accessories located on the underside of cover shall be 316 Stainless Steel.

9.2 Perimeter flashing anchors, concrete anchors or other hardware not exposed to the inside environment of tank shall be 316 Stainless Steel.

#### 10.0 Acceptable Manufacturer

All hardware is to be supplied or manufactured by Treadwell Group Pty Ltd of Australia, EcoEX™ division.



*SureLine® HD installation in New Zealand.*

SureLine® FRP Baffle Walls

**What is EcoEX™ SureLine® FRP Baffle Walls**

In-line with our offerings for odour control, Treadwell offers a premium solution to control flow in related applications with our multifunctional SureLine® range.

SureLine® fibreglass baffle walls are an effective solution to meet requirements in potable water and wastewater treatment flow control. SureLine® FRP baffle and partition walls compose of high grade fibreglass panels, angles and framing sections, engineered to your specifications. All SureLine® fibreglass baffle walls are certified AS 4020 for processing potable water.



**Ideal for New or Retrofit Basins**

SureLine® FRP baffle walls are a proven solution for both new and existing basins. These panels can withstand corrosion, unlike traditional materials, and are more cost effective. Being light in weight means quick and easy installation. Maintenance is also lessened as they can be taken down easily for cleaning and other purposes.

**Design Versatility and Flexibility**

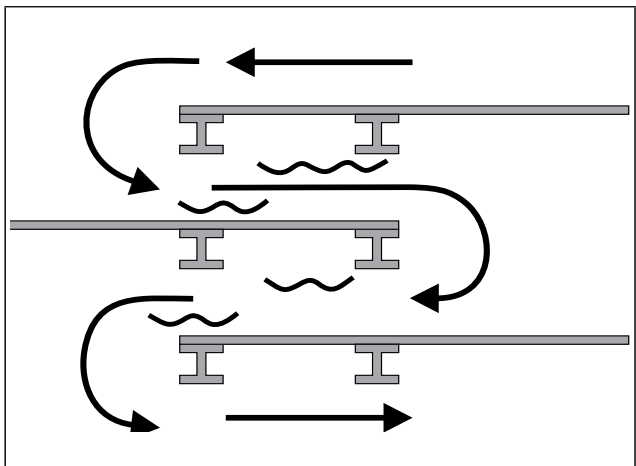

Baffles to control flow and increase residence time.

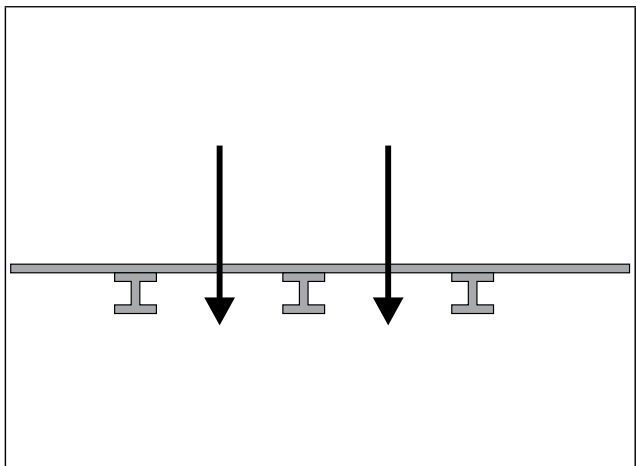

Partition to separate zones or enhance mixing.

**Benefits of SureLine® Baffle Walls**

1	Easy to install	3	Easy to remove scum
2	Relatively maintenance free	4	Light weight

# SureLine® FRP Baffle Walls Typical Configurations & Options

## Typical Configurations & Options

**Cantilivered Column Wall**

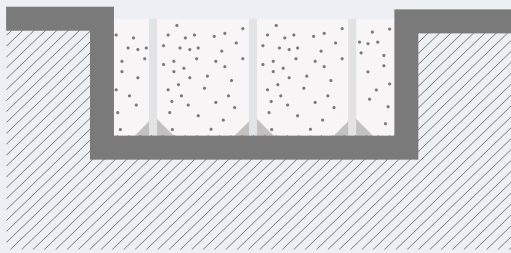

Non-braced columns may avoid interference with process equipment.

**Integrated Roof**

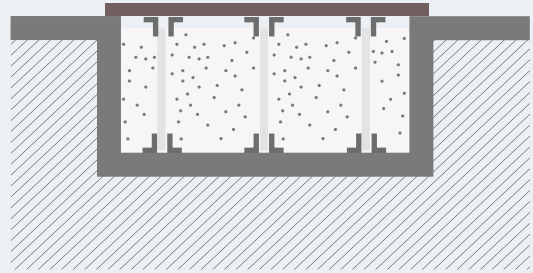

Baffle wall framing can be integrated with basin covers to reduce cost.

**Perforated Wall**



Baffle panels can be shop-perforated for increased water mixing and flow.

**Solid Wall with Bottom Void**

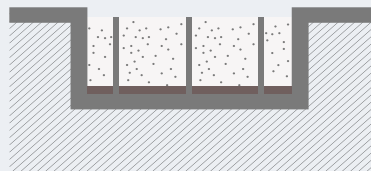

1-6" voids between baffle and basin bottom to ease sediments cleaning.

**Doors**

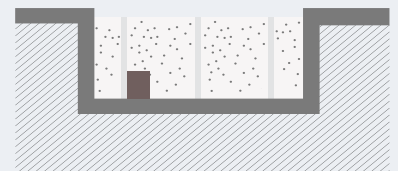

Baffle doors for man ways and access are available.

## SureLine® Baffle Panel Stacking

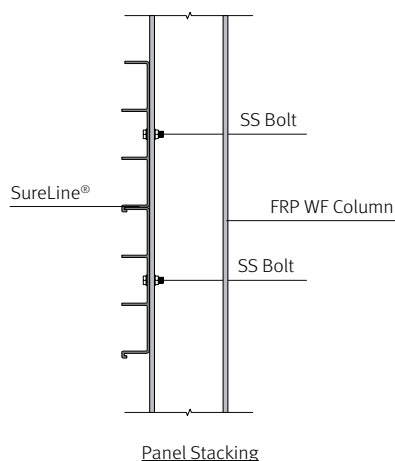

## Bolted FRP WF Column

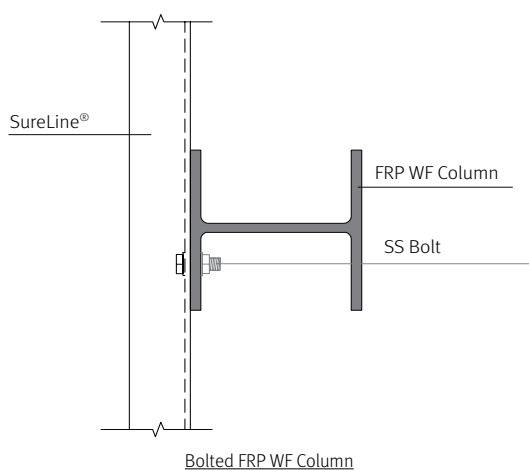



# SureLine® FRP Baffle Walls Specification

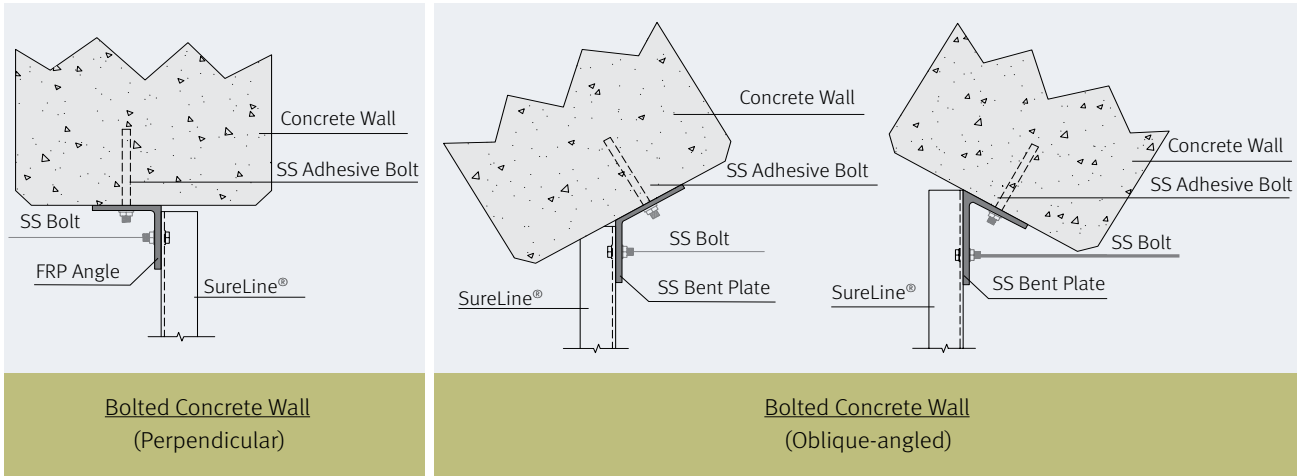

## SureLine® FRP Baffle Walls Typical Connections

### General

#### 1.0 Description of Work

1.1 The scope of this specification shall include materials for the fiberglass reinforced plastic (FRP) baffle wall System including FRP baffle wall panels; FRP columns; FRP angles; column base plates/angles; fasteners and connections.

#### 2.0 Design Criteria

- 2.1 Design load (greater of water differential or wind load)
  - 2.1.1 Water differential: \_\_\_\_\_ mm. (uniform load over wall)
  - 2.1.2 Wind load: \_\_\_\_\_ kPa uniform load
- 2.2 Deflection limit and factor of safety
  - 2.2.1 Baffle panels: L/D=\_\_\_\_\_; max defl=panel depth; FOS = 2.0
  - 2.2.2 Columns: L/D=100; FOS=2.5

### Products

#### 3.0 Manufacturer

3.1 Standard for design, characteristics, and performance is the SureLine® FRP baffle walls manufactured by Treadwell Group.

#### 4.0 Materials

- 4.1 FRP baffle panels, columns, and angle
  - 4.1.1 FRP baffle panels, columns, angles, and associated components shall be AS 4020 for potable water application (as required).

4.1.2 FRP structural materials shall exhibit these minimum properties:

Tensile Strength	206.8 MPA	ASTM D638
Compressive Strength	206.8 MPa	ASTM D695
Flexural Strength	206.8 MPa	ASTM D790

- 4.1.3 FRP materials shall include UV stabilized polyester resin; surfacing veil at top and bottom sides; grey colour.
- 4.1.4 Factory cut edges and drilled holes shall be sealed with AS 4020 approved material.
- 4.1.5 FRP baffle panels shall be 54mm depth; 4.8mm nominal thickness;
- 4.1.6 FRP columns shall be ArchitEX™ \_\_\_\_\_ with 50% glass fibre reinforcing (by wt.). Column base plates or angles shall be 304/316 Stainless Steel.
- 4.1.7 FRP angles shall be 9.5mm thick and 90 degrees.

#### 4.2 Hardware

- 4.2.1 Fasteners, anchors, and other structural hardware shall be 304/316 Stainless Steel.
- 4.2.2 Submerged anchors shall be epoxy adhesive type.

For expanded specification, please contact us.

## What is EcoEX™ Ducting and Stacks

Chemically and structurally engineered to resist a wide range of acids, alkalis solvents and corrosive fumes, EcoEX™ stacks and ducting are resistant to the damaging effects of the most consuming environments. In addition to their resistance to corrosion, pitting and scaling, EcoEX™ is unaffected by virtually all bacteriological corrosion and is constructed with built in protection against rust.



Engineering advice can be provided in-house for optimal design at Treadwell with products fabricated directly from plans in a made-to-order approach for a perfect fit every time.

### Treadwell Turnkey Design & Engineering Expertise

Constantly improving and innovating, Treadwell has garnered valuable in-depth experience in the FRP industry. We offer optimal and affordable FRP solutions and remain dedicated to aiding our clients avoid costs associated with using traditional alternatives.

With an in-house engineering and design team, you can rest assured that your project is seen from conception to execution by the Treadwell team. We are equipped to provide expert advice, ensuring that you, our client, are offered leading solutions that come from a culture that is forward thinking, responsible and proactive.

Our offering includes:

- Design certification
- Reporting
- CFD analysis
- Duct sizing based on design parameters.
- Sign off by our professional engineering staff, including RPEQ

### Typical Physical Properties of EcoEX™ Duct

General		Typical physical properties of 10mm thick laminate		
Specific Gravity	1.5		MPa	Psi
Linear Coefficient of Thermal Expansion (ASTM D696)	27 x 10 <sup>-6</sup> (m/m -degC)	Ultimate tensile strength (ASTM D638)	103	15,000
Thermal Conductivity	1.5 W/mK	Flexural strength (ASTM D790)	152	22,000
Glass Content	30 – 35%	Flexural modulus of elasticity (ASTM D790)	6,895	1,000,000
Barcol Hardness	35 to 45	Compressive strength (ASTM D695)	152	22,000

Specific physical properties are dependent on wall thickness, laminate construction and resin selection. Contact Treadwell for detailed specification and recommendations. Numbers stated are typical properties, and not to be taken as a specification.

### Ducting

EcoEX™'s ducting collection range in sizes from 100mm to 1800mm in diameter, with flow capacities extending to more than 30 cubic metres per second. All ducting, fittings and resin systems are customized to the specified application. Being lightweight, EcoEX™ FRP ducting is easy to install, without the need for heavy machinery. FRP does not sag when handling warm gases. Duct lengths are joined using a number of methods, all resulting in a leak-free outcome. Small sizes are available with rubber ring joints.

Fibreglass ducting is constructed by the contact moulded method for maximum chemical resistance. The exterior finish is a pigmented resin coat. All ducting is fabricated to international fibreglass standards. Treadwell also offers a number of different design life guarantees and warranties.



### Stacks

For dispersal of smaller residuals, EcoEX™ is proud to introduce our odour control stacks to minimize downstream odour effects. Stacks are the final end point in any air pollution control system. After scrubbers have lessened the levels of odours and noxious gases, our EcoEX™ stack is in place to aid the dispersal of smaller particles.

At Treadwell, we design and manufacture our stacks to suit the air flow and building heights. The stacks can be free standing, supported off a building, or guyed. A diffuser can be installed to increase the final dilution effect of a stack. The diffuser uses the energy of the gas going into the stack to induce fresh air into the discharge and effectively dilute the stack air. Another result of this is that the plumes can be less noticeable as the condensation plume is reduced. The gas velocity up the stack is selected to minimize condensation escaping.



### Typical Cross Section of EcoEX™ Fibreglass Ducts & Stacks

Fibreglass materials and technology are sourced internationally. Isophthalic polyester resins and vinyl ester resins are generally utilised, while other specialist resins can be applied to solutions for chlorinated polyesters and resins with varying grades of fire retardancy.

**Exterior Surface.** The final layer provides protection against weathering fumes, spillage and ultraviolet attack. This gives the duct a longer life and reduces maintenance expenses. Fibreglass ducting is constructed by the contact moulded method for maximum chemical resistance. The exterior finish is a pigmented resin coat. All ducting is fabricated to international fibreglass standards. Treadwell also offers a number of different design life guarantees and warranties.

**Inner Surface.** The interior surface 0.25mm - 0.5 mm, is a smooth resin rich laminate reinforced with surface veil. Providing optimum corrosion-resistance and a minimal friction factor when combined with the best resin for the specific chemical conditions.



**Next Interior Layer.** Duct in all diameters is built with an additional chemical resistant liner at least 2.5mm in thickness in the form of chopped strand mat which critically limits chemical permeation.

**Remaining Thickness.** Subsequent reinforcing layers of woven roving and chopped strand mat are used to build the duct to the desired wall thickness.

## EX-Series® Resin Systems Overview

When choosing a resin type for your application, we highly recommend you consult us to ensure important details such as corrosion, environment, temperature and requirements are taken into account. Dependent on these particulars, we will determine which resin system should be utilised for optimum performance over time.

**V-Series®** Vinylester Resin System is a high quality and is the most chemical resistant system offered in the industry and has been developed for use in environments where fibreglass/FRP products are subject to frequent and direct contact with the harshest of chemicals: including a broad range of acids and caustics. This system has a flame spread of 25 or less.

**I-Series®** is a premium Isophthalic Resin System. This system provides an intermediate level of chemical resistance and is the

correct choice for areas subjected to splash and spill contact with harsh chemicals. This system is an excellent general-purpose resin and is a more favourably priced alternative to the vinyl ester system. This system has a flame spread of 25 or less.

**O-Series®** is an architectural grade Polyester Resin System with a moderate chemical resistance. O-Series® is a good choice for commercial or light industrial applications, especially in areas where moisture is prevalent. O-Series® is often utilized for public infrastructure applications where it has been proven to outperform traditional timber decking products. It should be noted that Treadwell does not recommend O-Series for water and waste water treatment applications.

Treadwell also offers resin systems that are suitable for use in contact with potable drinking water and compliant with AS4020.

## Chemical Resistance Guide

Information contained in this guide is based on data collected from several years of actual industrial applications. Recommendations are based on conservative evaluations of the changes which occur in certain properties of replicate laminates after exposures of one year or longer, both in the laboratory and the field.

Temperatures are neither the minimum nor the maximum but represent standard test conditions (Room Temperature & 70°C). The products may be suitable at higher temperatures but individual test data should be required to establish such suitability. Contact Treadwell for any special applications that you may have.

The recommendations (• : resistant: – :not resistant) contained in this specification sheet are made without guarantee or representation as to results. We suggest that you evaluate these recommendations and suggestions in your own laboratory or actual field trial prior to use. Our responsibility for claims arising from breach of warranty, negligence, or otherwise is limited to the purchase price of the material.

Chemical	V-Series®		I-Series®	
	Room Temp	70°C	Room Temp	70°C
Acetaldehyde	—	—	—	—
Acetic Acid 0-25%	•	•	•	•
Acetic Acid 25-50%	•	•	•	—
Acetic Anhydride	—	—	—	—
Acetone	—	—	—	—
Acrylonitrile	—	—	—	—
Alcohol, Butyl	•	—	—	—
Alcohol, Ethyl 10%	•	66	—	—
Alcohol, Ethyl 100%	•	—	—	—
Alcohol, Isopropyl 10%	•	66	—	—
Alcohol, Isopropyl 100%	•	—	—	—
Alcohol, Methyl 10%	•	66	—	—
Alcohol, Methyl 100%	—	—	—	—
Alcohol, Methyl Isobutyl	•	66	—	—
Alcohol, Secondary Butyl	•	66	—	—
Aluminium	•	•	•	•
Aluminium Chloride	•	•	•	•
Aluminium Hydroxide	•	49	•	—
Aluminium Nitrate	•	•	•	•

Chemical	V-Series®		I-Series®	
	Room Temp	70°C	Room Temp	70°C
Aluminium Potassium Sulfate	•	•	•	•
Ammonia, Aqueous 0-10%	•	38	—	—
Ammonia, Gas	•	38	—	—
Ammonium Bicarbonate	•	49	•	—
Ammonium Bisulfite	•	49	—	—
Ammonium Carbonate	•	49	—	—
Ammonium Citrate	•	49	•	—
Ammonium Fluoride	•	49	—	—
Ammonium Hydroxide 5%	•	49	•	—
Ammonium Hydroxide 10%	•	49	•	—
Ammonium Hydroxide 20%	•	49	—	—
Ammonium Nitrate	•	49	•	•
Ammonium Persulfate	•	49	—	—
Ammonium Phosphate	•	49	—	—
Ammonium Sulfate	•	•	•	•
Arsenious Sulfate	•	•	•	—
O-Benzoyl Benzoic Acid	•	•	—	—
Barium Carbonate	•	•	•	—
Barium Chloride	•	•	•	—



# Chemical Resistance Guide

Chemical	V-Series®		I-Series®	
	Room Temp	70°C	Room Temp	70°C
Barium Hydroxide	•	49	—	—
Barium Sulfate	•	•	•	•
Barium Sulfide	•	•	—	—
Beer	•	49	•	—
Benzene	—	—	—	—
5% Benzene in Kerosene	•	•	•	—
Benzene Sulfonic Acid	•	•	•	•
Benzoic Acid	•	•	•	—
Benzyl Alcohol	•	—	—	—
Benzyl Chloride	—	—	—	—
<b>Brass Plating Solution:</b>				
– 3% Copper Cyanide	•	•	—	—
– 6% Sodium Cyanide	•	•	—	—
– 1% Zinc Cyanide	•	•	—	—
– 3% Sodium Carbonate	•	•	—	—
Butyl Acetate	—	—	—	—
Butyric Acid 0-50%	•	•	•	—
Butylene Glycol	•	•	•	•
Cadmium Chloride	•	•	•	—
<b>Cadmium Cyanide Plating Soln:</b>				
– 3% Cadmium Oxide	•	49	—	—
– 6% Sodium Cyanide	•	49	—	—
– 1% Caustic Soda	•	49	—	—
Calcium Bisulfate	•	•	•	•
Calcium Carbonate	•	•	•	—
Calcium Chlorate	•	•	•	•
Calcium Chloride	•	•	•	•
Calcium Hydroxide	•	49	•	—
Calcium Hypochlorite	•	49	•	—
Calcium Nitrate	•	•	•	•
Calcium Sulfate	•	•	•	•
Calcium Sulfite	•	•	•	•
Caprylic Acid	•	•	•	—
Carbon Dioxide	•	•	•	•
Carbon Disulfide	—	—	—	—
Carbon Monoxide	•	•	•	•
Carbon Tetrachloride	•	38	—	—
Carbon Acid	•	•	•	—
Castor Oil	•	•	•	•
Carbon Methyl Cellulose	•	49	—	—
Chlorinated Wax	•	•	—	—
Chlorine Doxide/Air	•	•	•	—
Chlorine Dioxide, Wet Gas	•	•	—	—
Chlorine, Dry Gas	•	•	—	—
Chlorine, Wet Gas	•	•	—	—
Chlorine, Liquid	—	—	—	—

Chemical	V-Series®		I-Series®	
	Room Temp	70°C	Room Temp	70°C
Chlorine, Water	•	•	—	—
Chloroacetic Acid 0-50%	•	38	—	—
Chlorobenzene	—	—	—	—
Chloroform	—	—	—	—
Chlorosulfonic Acid	—	—	—	—
Chromic Acid 20%	•	49	—	—
Chromic Acid 30%	—	—	—	—
Chromium Sulfate	•	•	•	•
Citric Acid	•	•	•	•
Coconut Oil	•	•	•	—
Copper Chloride	•	•	•	•
Copper Cyanide	•	•	—	—
Copper Fluoride	•	•	—	—
Copper Nitrate	•	•	•	•
<b>Copper Plating Solution:</b>				
– Copper Cyanide	•	•	—	—
– 10.5% Copper	•	•	—	—
– 4% Copper Cyanide	•	•	—	—
– 6% Rochelle Salts	•	•	—	—
<b>Copper Brite Plating:</b>				
– Caustic Cyanide	•	38	—	—
<b>Copper Plating Solution:</b>				
– 45% Copper Fluoroborate	•	•	—	—
– 19% Copper Sulfate	•	•	—	—
– 8% Sulfuric Acid	•	•	—	—
<b>Copper Matte Dipping Bath:</b>				
– 30% Ferric Chloride	•	•	—	—
– 19% Hydrochloric	•	•	—	—
<b>Copper Pickling Bath:</b>				
– 10% Ferric Sulfate	•	•	—	—
– 10% Sulfuric Acid	•	•	—	—
Copper Sulfate	•	•	•	•
Corn Oil	•	•	•	—
Corn Starch-Slurry	•	•	•	—
Corn Sugar	•	•	•	—
Cottonseed Oil	•	•	•	—
Crude Oil, Sour	•	•	•	—
Crude Oil, Sweet	•	•	•	—
Cyclohexane	•	49	•	—
Detergents, Sulfonated	•	•	•	—
Di-Ammonium Phosphate	•	•	•	—
Dibromophenol	—	—	—	—
Dibutyl Ether	•	49	—	—
Dichloro Benzene	—	—	—	—
Dichloroethylene	—	—	—	—
Diesel Fuel	•	•	•	—

## Chemical Resistance Guide

Chemical	V-Series®		I-Series®	
	Room Temp	70°C	Room Temp	70°C
Diethylene Glycol	•	•	•	—
Dimethyl Phthalate	•	•	—	—
Diethyl Phthalate	•	•	—	—
Dipropylene Glycol	•	•	•	—
Dodecyl Alcohol	•	•	—	—
Esters, Fatty Acids	•	•	•	•
Ethyl Acetate	—	—	—	—
Ethyl Benzene	—	—	—	—
Ethyl Ether	—	—	—	—
Ethylene Glycol	•	•	•	•
Ethylene Dichloride	—	—	—	—
Fatty Acids	•	•	•	•
Ferric Chloride	•	•	•	•
Ferric Nitrate	•	•	•	•
Ferric Sulfate	•	•	•	•
Ferrous Chloride	•	•	•	•
Ferrous Nitrate	•	•	•	•
Ferrous Sulfate	•	•	•	•
8-8-8 Fertiliser	•	49	•	—
<b>Fertiliser:</b>				
– Urea Ammonium Nitrate	•	49	—	—
Fuel Gas	•	•	—	—
Fluoboric Acid	•	49	—	—
Fluosilicic Acid 0-20%	•	•	—	—
Formaldehyde	•	•	•	—
Formic Acid	•	•	•	—
Fuel Oil	•	•	•	—
Gas Natural	•	•	•	—
Gasoline, Auto	•	•	•	—
Gasoline, Aviation	•	•	•	—
Gasoline, Ethyl	•	•	•	—
Gluconic Acid	•	•	•	—
Gasoline, Sour	•	•	•	—
Glucose	•	•	•	•
Glycerine	•	•	•	•
Glycol, Ethylene	•	•	•	•
Glycol, Propylene	•	•	•	•
Glycolic Acid	•	•	•	—
<b>Gold Plating Solution:</b>				
– 63% Potassium Ferrocyanide	•	•	—	—
– 2% Potassium Gold Cyanide	•	•	—	—
– 8% Sodium Cyanide	•	•	—	—
Heptane	•	•	•	—
Hexane	•	•	•	—
Hexylene Glycol	•	•	•	•
Hydraulic Fluid	•	•	•	—

Chemical	V-Series®		I-Series®	
	Room Temp	70°C	Room Temp	70°C
Hydrobromic Acid 0-25%	•	•	•	—
Hydrochloric Acid 0-37%	•	•	•	—
Hydrocyanic Acid	•	•	•	—
Hydrofluoric Acid 10%	•	—	—	—
Hydrofluosilicic Acid, 10%	•	•	—	—
Hydrogen Bromide, Wet Gas	•	•	—	—
Hydrogen Chloride, Dry Gas	•	•	—	—
Hydrogen Chloride, Wet Gas	•	•	—	—
Hydrogen Peroxide	•	49	—	—
Hydrogen Sulfide, Dry	•	•	•	—
Hydrogen Sulfide, Aqueous	—	•	•	—
Hydrogen Fluoride, Vapour	•	•	—	—
Hydrosulfite Bleach	•	49	—	—
Hydrochloric Acid 0-10%	—	—	—	—
<b>Iron Plating Solution:</b>				
– 45% Fecl: 15% Cacl	•	•	—	—
– 20% Fecl: 11% (Nh4)2 So4	•	•	—	—
<b>Iron And Steel Claeaning Bath:</b>				
–9% Hydrochloric: 23% Sulfuric	•	•	—	—
Isopropyl Amine	•	38	—	—
Isopropyl Palmitate	•	•	•	•
Jet Fuel	•	•	•	—
Kerosene	•	•	•	—
Lactic Acid	•	•	•	—
Lauroryl Chloride	•	•	—	—
Lauric Acid	•	•	•	—
Lead Acetate	•	•	•	—
Lead Chloride	•	•	•	—
Lead Nitrate	•	•	•	—
<b>Lead Plating Solution:</b>				
–.8% Fluoboric, 0.4% Boric Acid	•	•	—	—
Levulinic Acid	•	•	•	—
Linseed Oil	•	•	•	•
Lithium Bromide	•	•	•	•
Lithium Sulfate	•	•	•	•
Magnesium Bisulfite	•	•	•	—
Magnesium Carbonate	•	•	•	—
Magnesium Chloride	•	•	•	•
Magnesium Hydroxide	•	60	—	—
Magnesium Nitrate	•	•	•	—
Magnesium Sulfate	•	•	•	•
Maleic Acid	•	•	•	•
Mercuric Chloride	•	•	•	—
Mercurous Chloride	•	•	•	—
Methylene Chloride	—	—	—	—
Methyl Ethyl Ketone	—	—	—	—

# Chemical Resistance Guide

Chemical	V-Series®		I-Series®	
	Room Temp	70°C	Room Temp	70°C
Methyl Isobutyl Carbitol	—	—	—	—
Methanol (See Alcohol)	•	•	•	—
Methyl Isobutyl Ketone	—	—	—	—
Methyl Styrene	—	—	—	—
Mineral Oils	•	•	•	•
Molybdenum Disulfide	•	•	•	—
Monochloro Acetic Acid	—	—	—	—
Monoethanolamine	—	—	—	—
Motor Oil	•	•	•	•
Myristic Acid	•	•	—	—
Naptha	•	•	•	•
Napthalene	•	•	•	—
Nickel Chloride	•	•	•	•
Nickel Nitrate	•	•	•	•
<b>Nickel Plating:</b>				
– 8% Lead, 0.8% Flouboric Acid	•	•	—	—
– 0.4% Boric Acid	•	•	—	—
<b>Nickel Plating:</b>				
– 11% Nickel Sulfate	•	•	•	—
– 2% Nickel Chloride	•	•	•	—
– 1% Boric Acid	•	•	•	—
<b>Nickel Plating:</b>				
– 44% Nickel Sulfate	•	•	•	—
– 4% Ammonium Chloride	•	•	•	—
– 4% Boric Acid	•	•	•	—
Nickel Sulfate	•	•	•	•
Nitric Acid 0-5%	•	•	•	•
Nitric Acid 20%	•	49	—	—
Nitric Acid Fumes	—	—	—	—
Nibrobenzene	—	—	—	—
Octanoci Acid	•	•	•	—
Oil, Sour Crude	•	•	•	•
Oil, Sweet Crude	•	•	•	•
Oleic Acid	•	•	•	•
Oleum (Fuming Sulfuric)	—	—	—	—
Olive Oil	•	•	•	•
Oxalic Acid	•	•	•	•
<b>Peroxide Bleach:</b>				
– 25% Peroxide 95%	•	•	•	•
– 0.025% Epsom Salts	•	•	•	•
– 5% Sodium Silicate 42.Be	•	•	•	•
– 1.4% Sulfuric Acid 66.Be	•	•	•	•
Phenol	—	—	—	—
Phenol Sulfonic Acid	—	—	—	—
Phosphoric Acid	•	•	•	•
Phosphoric Acid Fumes	•	•	•	•

Chemical	V-Series®		I-Series®	
	Room Temp	70°C	Room Temp	70°C
Phosphorous Pentoxide	•	•	•	•
Phosphorous Trichloride	—	—	—	—
Phthalic Acid	•	•	•	•
Pickling Acids (Sulfuric & Hydrochloric)	•	•	•	•
Picric Acid, Alcoholic	—	—	—	—
Polyvinyl Acetate Latex	•	•	•	—
Polyvinyl Alcohol	•	38	•	—
Polyvinyl Chloride Latex W/35 (Parts Dop)	•	49	—	—
Potassium Aluminium Sulfate	•	•	•	•
Potassium Bicarbonate	•	60	•	—
Potassium Bromide	•	38	•	—
Potassium Carbonate	•	60	•	—
Potassium Chloride	•	•	•	•
Potassium Dichromate	•	60	•	—
Potassium Ferricyanide	•	•	•	•
Potassium Ferrocyanide	•	•	•	•
Potassium Hydroxide	•	66	—	—
Potassium Nitrate	•	•	•	•
Potassium Permanganate	•	60	•	—
Potassium Persulfate	•	•	•	—
Potassium Sulfate	•	•	•	•
Propionic Acid 1-50%	•	49	—	—
Propionic Acid 50-100%	—	—	—	—
Propylene Glycol	•	•	•	•
Pulp Paper Mill Effluent	•	•	•	—
Pyridine	—	—	—	—
Salicylic Acid	•	60	—	—
Sebacic Acid	•	•	—	—
Selenious Acid	•	•	—	—
Silver Nitrate	•	•	•	•
<b>Silver Plating Solution:</b>				
– 44% Silver Cyanide	•	•	—	—
– 7% Potassium Cyanide	•	•	—	—
– 5% Sodium Cyanide	•	•	—	—
– 2% Potassium Carbonate	•	•	—	—
Soaps	•	•	•	—
Sodium Acetate	•	•	•	—
Sodium Benzoate	•	•	•	—
Sodium Bicarbonate	•	•	•	•
Sodium Bifluoride	•	49	•	—
Sodium Bisulfate	•	•	•	•
Sodium Bisulfite	•	•	•	•
Sodium Bromate	•	60	•	•
Sodium Bromide	•	•	•	•
Sodium Carbonate 0-25%	•	•	•	—

## Chemical Resistance Guide

Chemical	V-Series®		I-Series®	
	Room Temp	70°C	Room Temp	70°C
Sodium Chlorate	•	•	•	—
Sodium Chloride	•	•	•	•
Sodium Chlorite	•	•	•	—
Sodium Chromite	•	•	•	•
Sodium Cyanide	•	•	•	—
Sodium Dichromate	•	•	•	•
Sodium Di-Phosphate	•	•	•	•
Sodium Ferricyanide	•	•	•	•
Sodium Fluoride	•	49	•	—
Sodium Fluoro Silicate	•	49	—	—
Sodium Hexametaphosphates	•	38	—	—
Sodium Hydroxide 0-5%	•	66	—	—
Sodium Hydroxide 5-25%	•	66	—	—
Sodium Hydroxide 50%	•	66	—	—
Sodium Hydrosulfide	•	•	•	—
Sodium Hypochlorite	•	66	•	—
Sodium Lauryl Sulfate	•	•	•	•
Sodium Mono-Phosphate	•	•	•	•
Sodium Nitrate	•	•	•	•
Sodium Silicate	•	•	•	—
Sodium Sulfate	•	•	•	•
Sodium Sulfide	•	•	•	—
Sodium Sulfite	•	•	•	—
Sodium Tetra Borate	•	•	•	•
Sodium Thiocyanate	•	•	—	—
Sodium Thiosulfate	•	•	•	—
Sodium Tripolyphosphate	•	•	•	—
Sodium Xylene Sulfonate	•	•	•	—
Sodium Solutions	•	•	•	—
Sodium Crude Oil	•	•	•	•
Soya Oil	•	•	•	•
Stannic Chloride	•	•	•	•
Stannous Chloride	•	•	•	•
Stearic Acid	•	•	•	•
Styrene	—	—	—	—
Sugar, Beet And Cane Liquor	•	•	•	—
Sugar, Sucrose	•	•	•	•
Sulfamic Acid	•	•	•	—
Sulfanilic Acid	•	•	•	—
Sulfated Detergents	•	•	•	—
Sulfur Dioxide, Dry Or Wet	•	•	—	—
Sulfur Trioxide/Air	•	•	—	—
Sulfuric Acid 0-30%	•	•	•	•
Sulfuric Acid 30-50%	•	•	—	—
Sulfuric Acid 50-70%	•	49	—	—
Sulfurous Acid	•	38	—	—

Chemical	V-Series®		I-Series®	
	Room Temp	70°C	Room Temp	70°C
Superphosphoric Acid (76% P2 O5)	•	•	•	—
Tall Oil	•	60	•	—
Tannic Acid	•	66	•	—
Tartaric Acid	•	•	•	•
Thionyl Chloride	—	—	—	—
<b>Tin Plating:</b>				
– 18% Stannous Fluoroborate	•	•	—	—
– 7% Tin	•	•	—	—
– 9% Fluoroboric Acid	•	•	—	—
– 2% Boric Acid	•	•	—	—
Toluene	—	—	—	—
Toluene Sulfonic Acid	•	•	—	—
<b>Transformer Oils:</b>				
– Mineral Oil Types	•	•	•	•
– Chloro-Phenyl Types)	•	•	•	•
Trichlor Acetic Acid	•	•	•	—
Trichlorethylene	—	—	—	—
Trichloropentol	—	—	—	—
Tricresyl Phosphate	•	49	—	—
Tridecylbenzene Sulfonate	•	•	•	—
Trisodium Phosphate	•	•	•	—
Turpentine	•	38	—	—
Urea	•	38	—	—
Vegetable Oils	•	•	•	•
Vinegar	•	•	•	•
Vinyl Acetate	—	—	—	—
<b>Water:</b>				
– Deionised	—	—	—	—
– Demineralised	•	•	•	•
– Distilled	•	•	•	•
– Fresh	•	•	•	•
– Salt	•	•	•	•
– Sea	•	•	•	•
White Liquor (Pulp Mill)	•	•	•	—
Xylene	—	—	—	—
Zinc Chlorate	•	•	•	•
Zinc Nitrate	•	•	•	•
<b>Zinc Plating Solution:</b>				
– 9% Zinc Cyanide	•	49	—	—
– 4% Sodium Cyanide	•	49	—	—
–9% Sodium Hydroxide	•	49	—	—
<b>Zinc Plating Solution:</b>				
– (49% Zinc Fluoroborate	•	•	•	—
– 5% Ammonium Chloride	•	•	•	—
– 6% Ammonium Fluoroborate	•	•	•	—
Zinc Sulfate	•	•	•	•



# Bolivar Water Treatment Plant

Every year, SA Water manages and treats millions of litres of sewerage in South Australia. SA Water was proposing to substantially increase capacity at its Bolivar Wastewater Treatment Plant to help meet future population and industry growth in the surrounding region. As part of SA Water's plan to upgrade the South Australia plant to increase capacity of up to 50% in certain areas, Treadwell had been tasked to aid in fulfilling the expansion of the facility. \$24.6 million has been budgeted for the capacity upgrade in the 2015 period, with additional expenditure in future years to be determined through detailed design and tendering processes.

## Project Challenges

- Previous plant was suffering from corrosion of concrete in a number of key portions of the plant.
- Elements to allow inlet screens and clarifiers to accommodate the new projected flows were required.
- The cost of maintenance of the facility is a concern once installed as experience with previous materials required consistent attention to upkeep the usability of the centre.

## PROJECT INFORMATION

Project Category:	Waste Water treatment plant
Scope of Work:	Upgrading & Increasing the capacity of Bolivar waste water
Treadwell Products:	EcoEX™ SURELINE® Odour Control Covers ArchiTEX™ Structural Profiles
Value:	\$ 850,000

## Treadwell Solution:

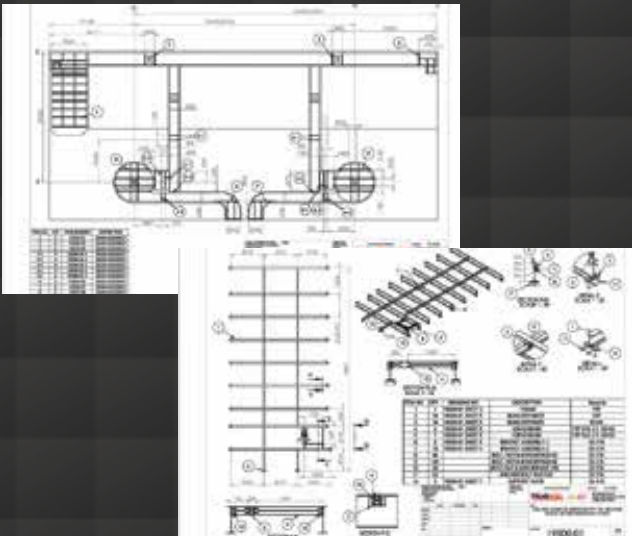

1

High performance EcoEX™ Sureline® tank covers are manufactured from premium grade corrosion resistant fibreglass resins and have reinforced membranes that contain odours.

2

The extensive range of ArchiTEX™ provided the durable and strong components in the construct of inlets and other framework specified.

3

FRP is simply fabricated and modified on site. This means there is no need for any hot works permit.

4

Being lightweight and easy to install, FRP is very manageable during construction.

5

Given the nature of FRP, any system utilising it is virtually maintenance free, thus keeping maintenance costs as low as possible.

# Black Rock Recycled Water Plant

This Victorian Recycled Water Plant is located in Connewarre and provides high quality recycled water for residential, industrial, agricultural and community uses. The precinct is also home to the existing water reclamation facility and bio solids drying plant. The plant supplies high quality Class A and consistent quality Class C recycled water for a range of customers and uses.

To meet growing demand, the site was to be expanded. Treadwell was selected to aid in the design and supply the necessary SureLine® odour control covers, supported by ArchitEX™ structural proles, as a solution to the challenges the project posed.

## Project Challenges

- A high live loading of 5Kpa was specified and a maximum deflection of 7mm (at 5Kpa) was required.
- The replacement FRP covers had to be manufactured to suit the specific sizes to match the existing structures.
- Exposure to the corrosive wastewater environment was also a concern.
- Maintenance of structure over time was required to ensure the least amount of time, effort and cost in this remote area.
- Being large structures, there was concern that these stacks might affect radio frequencies.
- Electrical conductivity of these structures was also deemed to be a safety hazard.

## PROJECT INFORMATION

Project Category:	Wastewater recycling plant extension
Scope of Work:	New inlet works
Treadwell Products:	SureLine® Odour Control Covers ArchitEX™ Structural Proles
Value:	\$ 160,000

## Treadwell Solution:

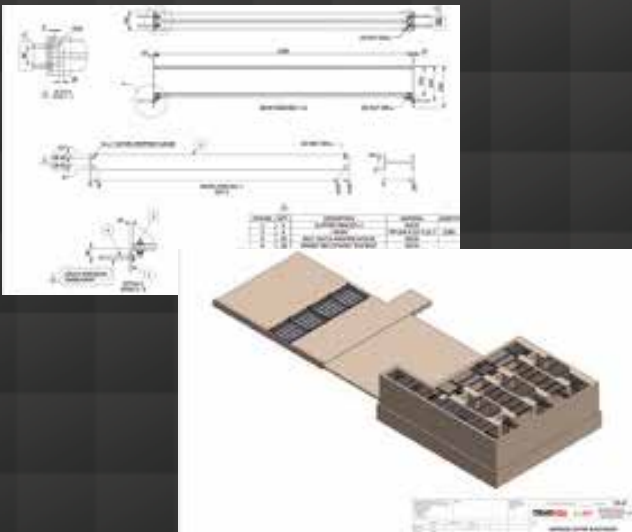

1

Treadwell's EcoEX™ SureLine® were designed and engineered to meet the deflection and live load requirements as well as customised to suit the sizes of the existing structures.

2

Durable and corrosion resistant FRP was chosen as the material of choice to avoid long term environmental issues

3

Given the nature of FRP, any system utilising it is virtually maintenance free, thus keeping maintenance costs as low as possible.

4

FRP is transparent to radio frequency transmission and is non-conductive in nature. This makes the material ideal for applications that need to avoid electrical currents and radio frequency.



# Wanganui Sewage Treatment Plant

The Wanganui wastewater treatment plant in New Zealand needed to be upgraded with a solution that was robust and could capture the odour produced from the plant. As a part of this upgrade, Treadwell worked closely with the mechanical contractor, builder and council to deliver an odour control cover solution using Treadwell's EcoEX™ SureLine® HD system. In addition to containing corrosive gases, this project was designed to bear loads allowing safe access across the covers.

## Project Challenges

- Large spans between tank walls.
- Designed to facilitate safe access for walking traffic across the panels in accordance with the roof loading requirements.
- Exposure to highly corrosive hydrogen sulfide gas.
- Required anti-slip surface that met P5 rating standards

## PROJECT INFORMATION

Project Category:	Water Infrastructure
Scope of Work:	Odour control cover system
Treadwell Products:	EcoEX™ SureLine® Heavy Duty panels
Value:	\$ 400,000

## Treadwell Solution:



1

Treadwell's high performance EcoEX™ SureLine® HD panels are manufactured from premium grade, corrosion-resistant fibreglass resins.

2

The panels for this project were designed and customized to meet live load requirements.

3

FRP is simply fabricated and modified on site. This means there is no need for any hot works permit.

4

Being lightweight and easy to install, FRP is very manageable during construction.

5

Given the nature of FRP, any system utilising it is virtually maintenance free, thus keeping maintenance costs as low as possible.





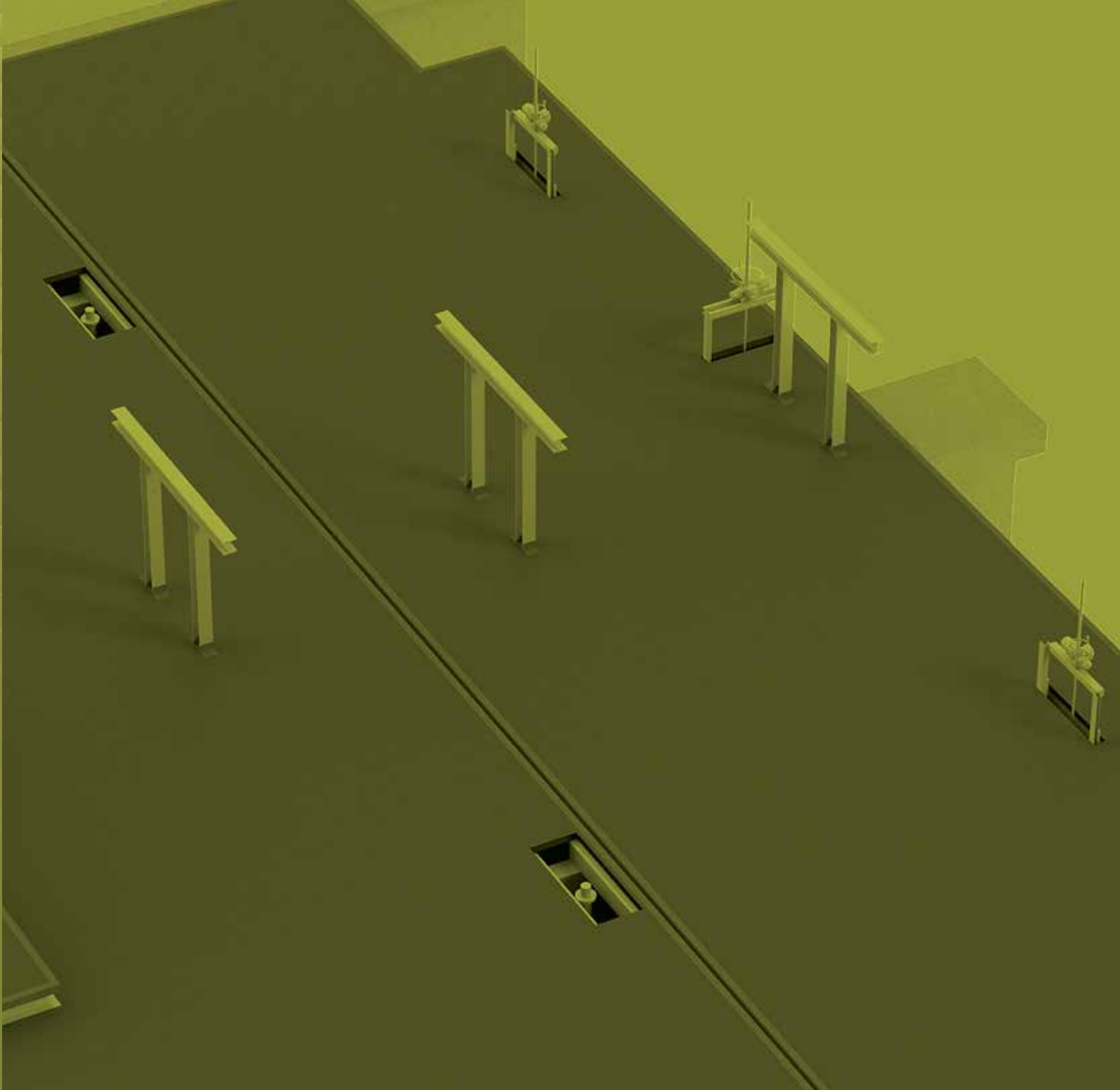
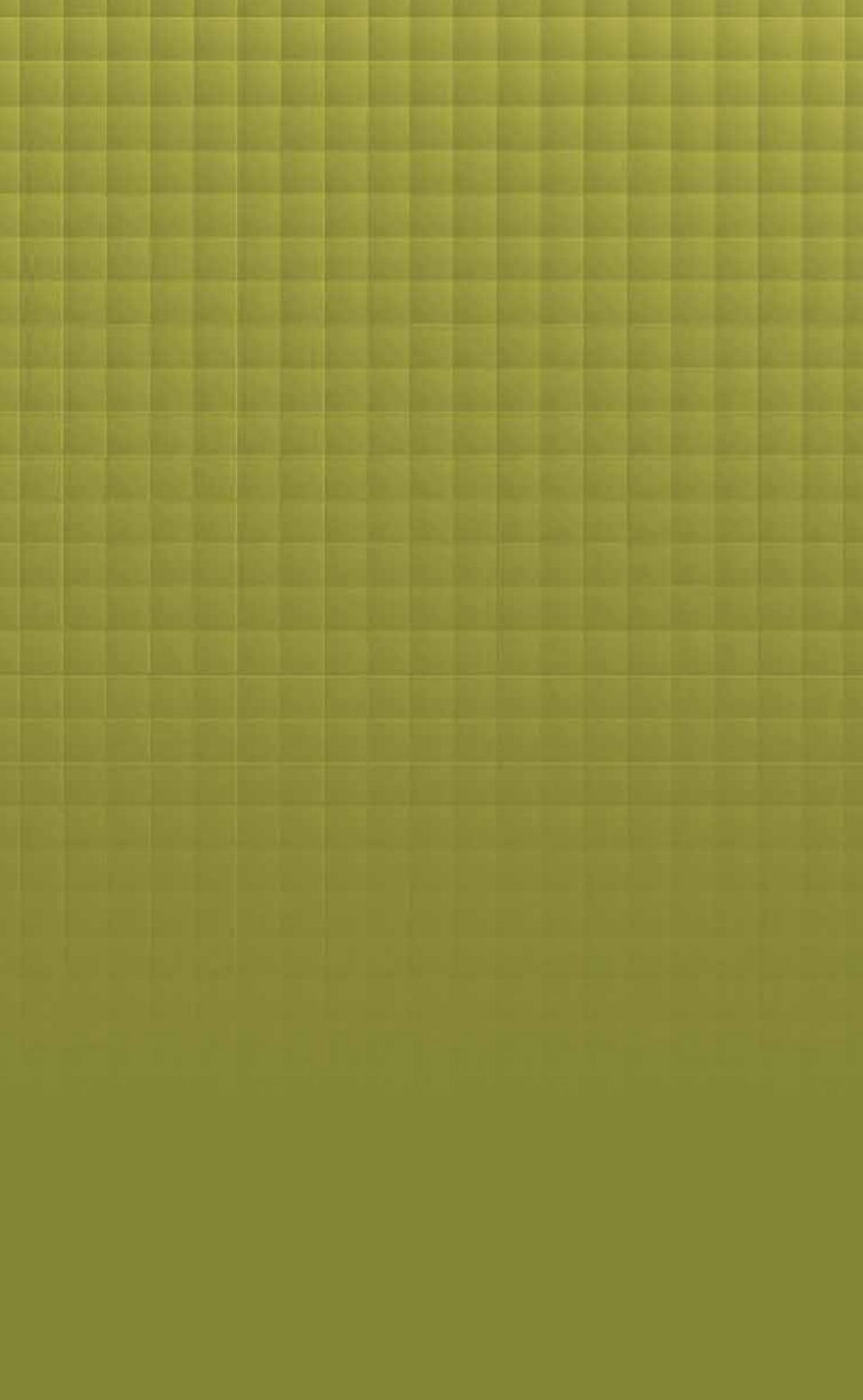

## **TREADWELL™**

Treadwell brands mentioned in this document are all registered brands of Treadwell Group Pty Ltd. All pictures and information are supplied as a guide only. The complete range of Treadwell products are developed, refined, made to meet and exceed stringent specifications for the worldwide market.

Important Note: Sales of products are subject to our Terms and Conditions which are available upon request. All specifications and photos are a guide only and are subject to change without notice. Please ring to confirm details. Treadwell products stated only comply with relevant standards mentioned within this publication when installed and used as they are designed to be.

