



The Treadwell team is delighted to introduce the latest revision of our ArchitEX™ Structural Product Guide, showcasing the largest range of Fibreglass Reinforced Plastic (FRP) profiles in the market and the ultimate tool for designing FRP structures.

The data in this FRP Structural Product Guide has been collated to ensure that engineers and architects have the ideal reference available to them while designing structures that incorporate FRP pultrusions.

While this guide offers a huge resource of information and statistics relevant to FRP structural profiles, it is impossible to embrace the flexibility and constant evolution of the ArchitEX™ FRP composite range in one publication. To ensure that you have the most up to date information on the ArchitEX™ range of profiles and applications or to simply draw on our team's experience in this unique industry, contact us via the relevant numbers or visit www.treadwellgroup.com.au.

This product guide is also available online, so if you are concerned that your copy may not be the latest, you can request an updated hardcopy or download it at www.treadwellgroup.com.au.



Interlocking & Decking Product Guide

Global leaders in the design and supply of fibreglass Reinforced Plastic (FRP) Interlocking Deckboards

A BRIEF HISTORY

Treadwell Group is one of the most established names in the supply of Access Systems throughout Australia. Our centrally located Adelaide fabrication facility, coupled with our second to none distribution network across Australia, and our commitment to quality and testing, allows our technical staff to provide engineering and design assistance for any project.

With a broad history of installation in a wide range of challenging applications, including industrial process plants, mining applications, marine and coastal environments, as well as public infrastructure, Treadwell has the experience to help you specify the right resin systems and products every time.

If you have any unique design problems, chances are we've encountered something similar before. Get in contact today.



Treadwell Group Pty Ltd

Australia
P 1800 246 800
sales@treadwellgroup.com.au
treadwellgroup.com.au

New Zealand
P 0800 244 600
sales@treadwellgroup.co.nz
treadwellgroup.co.nz

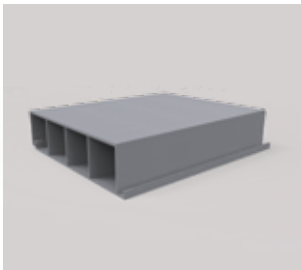

03	Resin Systems
04	SureLine® Standard FRP Panel
06	SureLine® Medium Duty FRP Panel
08	SureLine® Heavy Duty FRP Panel
10	UnidEX® FRP Deck Panel
	TreadSLAB®
11	TreadSLAB® 45
12	TreadSLAB® 50
12	TreadSLAB® 100
14	Chemical Resistance Guide
18	Case Studies



Quality Policy

Quality is at the forefront of Treadwell Access Systems' working practices. With over 15 years of manufacturing to the highest quality standards, Treadwell Access Systems prides itself on its implementation of strict quality control measures, and strives to supply products that surpass customers' expectations. The company works on a policy of continuous improvement.



Environmental Policy

Treadwell Access Systems is conscious of the impact it has on the environment and its associated responsibilities. The company is committed to ensuring its operations satisfy both legal obligations and moral duties. Treadwell has been committed to sustainability for many years and is not just responding to current trends.

Resin Systems

When choosing a resin type for your application, we highly recommend you consult with us in relation to the application to ensure the correct resin is specified. Considerations such as corrosion, environment, temperature, fire resistance, smoke and smoke toxicity requirements must be taken into account, and will dictate which resin system should be utilised for optimum performance over time. Below is an overview of the resin systems offered in the ArchitEX™ range.

O-Series® is an architectural grade polyester resin system with an intermediate level of chemical resistance, and is a good choice for commercial or light industrial applications, especially in areas where moisture is prevalent. O-Series® is often utilised for public infrastructure applications where it has been proven to outperform traditional timber decking products. This system is available with or without fire retardant additives.

I-Series® is a premium isophthalic resin system. This system provides an intermediate level of chemical resistance and is the correct choice for areas subjected to splash and spill contact with harsh chemicals. This system is an excellent general purpose resin and is a more favourably priced alternative to the vinyl ester system. This system has a flame spread of 25 (approximately 15) or less.

V-Series® Vinyl ester resin is the most high quality chemical resistant system offered in the industry and has been developed for use in environments where FRP products are subject to frequent and direct contact with the harshest of chemical, including a broad range of acids and caustics. This system has a flame spread of 25 (approximately 15) or less.

P-Series® The phenolic resin system is a system designed specifically for use where fire resistance, low smoke and low toxic fumes are critical. P-Series® is typically used in offshore applications and confined spaces where such criteria are an absolute necessity. This system is tested in accordance with ASTM E-84. Various products also conforming to US Coast Guard Approvals, Level 2 and 3, are also offered by Treadwell. This particular resin system has a flame spread rating of 5 and a smoke density rating of 5.

Standards Resin Systems Comparison Chart

	Chemical Resistance	Fire Retardance	Low Smoke	Halogen Free	Temperature Performance
O-Series® Polyester	● ● ●	● ● ● ●	—	—	● ● ●
I-Series® Isophthalic	● ● ● ● ●	● ● ● ● ●	—	—	● ● ● ●
V-Series® Vinyl Ester	● ● ● ● ●	● ● ● ● ●	—	—	● ● ● ● ●
P-Series® Phenolic	● ● ● ●	● ● ● ● ●	● ● ● ●	● ● ● ● ●	● ● ● ● ●

ArchitEX™ Features and Benefits vs. Traditional Alternatives

	ArchitEX™	Stainless Steel	Galvanised Steel	Aluminium	Polyurethane
Chemical Resistance	● ● ● ● ●	● ● ● ●	●	● ● ●	● ● ● ●
Strength	● ● ● ● ●	● ● ● ● ●	● ● ● ● ●	● ● ● ● ●	● ● ●
Lightweight	● ● ● ● ●	●	●	● ● ● ● ●	● ● ●
Electrical Resistance	● ● ● ● ●	●	●	●	● ● ● ● ●
Cost Effectiveness	● ● ● ● ●	● ● ●	● ● ● ●	● ●	● ● ● ● ●

SureLine® Standard Panel

Part: SureLine® Standard Panel

Part Number: ARX-SL054

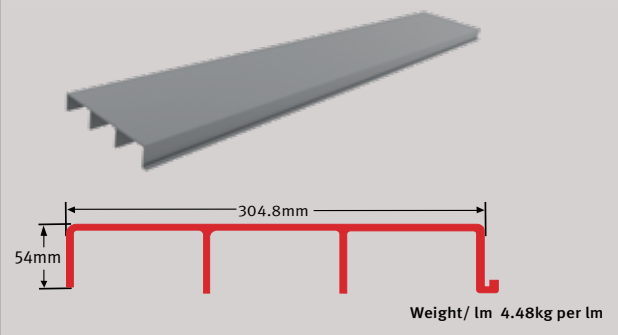

A_w	1036 mm ²	W_t	4.48 kg/m
I	765865mm ⁴	S	14798 mm ³

Span (mm)	Maximum Load (kPa)	Deflection (kPa)								
		L/D=120	L/D=150	L/D=180	L/D=220	L/D=250	L/D=300	L/D=350	L/D=400	L/D=500
400	99.98									80.79
600	44.44							38.27	33.49	26.79
800	25.00					23.59	19.66	16.85	14.74	11.79
1000	16.00				14.00	12.32	10.27	8.80	7.70	6.16
1200	11.11			10.02	8.20	7.21	6.01	5.15	4.51	3.61
1400	8.16		7.62	6.35	5.20	4.57	3.81	3.27	2.86	2.29
1600	6.25		5.13	4.27	3.50	3.08	2.56	2.20	1.92	1.54
1800	4.94	4.52	3.61	3.01	2.46	2.17	1.81	1.55	1.35	1.08
2000	4.00	3.30	2.64	2.20	1.80	1.58	1.32	1.13	0.99	0.79
2200	3.31	2.48	1.99	1.66	1.35	1.19	0.99	0.85	0.74	0.60
2400	2.78	1.92	1.53	1.28	1.04	0.92	0.77	0.66	0.57	0.46
2600	2.37	1.51	1.21	1.01	0.82	0.72	0.60	0.52	0.45	0.36
2800	2.04	1.21	0.97	0.81	0.66	0.58	0.48	0.41	0.36	0.29
3000	1.78	0.98	0.79	0.66	0.54	0.47	0.39	0.34	0.29	0.24
3200	1.56	0.81	0.65	0.54	0.44	0.39	0.32	0.28	0.24	0.19

Installation

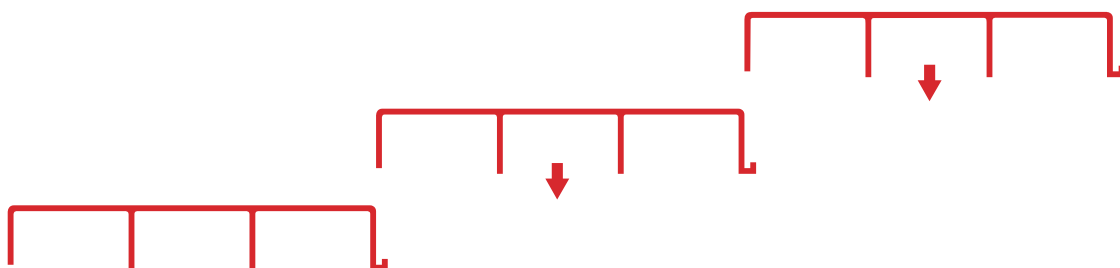

General

1.0 Scope

- 1.1 Scope of work shall include materials for fibreglass reinforced plastic (FRP) odour control covers including: EcoEX™ SureLine® odour control cover deck panels; ArchitEX™ FRP structural supports, EcoEX™ SureLine® flashing and trim, fasteners and anchors, EcoEX™ SureLine® gaskets.
- 1.2 SureLine® odour control covers shall be designed by Treadwell to be practicably odour secure unless specified otherwise.

2.0 Standards/ Related Documents

- 2.1 The odour control covers shall adhere to the applicable sections of:
 - 2.1.1 ASTM E84 Surface Burning Characteristics Of Building Materials
 - 2.1.2 ASTM D638 Standard Test Method For Tensile Properties Of Plastics
 - 2.1.3 ASTM D695 Standard Test Method For Compressive Properties Of Plastics
 - 2.1.4 ASTM D790 Standard Test Method For Flexural Properties Of Plastics
 - 2.1.5 AS 1170 Structural Design Actions

3.0 Design Criteria

- 3.1 Design Loads
 - 3.1.1 Wind Uplift _____ kPa
 - 3.1.2 Dead Load _____ kPa
 - 3.1.3 Live Loads _____ kPa
- 3.2 Cover Panel Removability
 - 3.2.1 Each SureLine® odour control cover panel shall be removable without having to remove no more than its two adjacent panels.
 - 3.2.2 Each SureLine® odour control cover panel shall be removable vertically and without cutting of a cover component.

4.0 Submittals

- 4.1 Shop drawings shall be submitted by Treadwell (unless provided by the client) displaying clearly material sizes, types, styles, product codes and including types and sizes of fasteners as well as a layout if required.
- 4.2 Technical data and sample pieces can also be submitted if required.

5.0 Quality Assurance

Quality surrounds every aspect of Treadwell's commitment to our superior products and efficiency. Treadwell's quality assurance strictly adheres to the high quality control standards placed to conform to relevant specifications, codes, Australian Standards and contractual requirements in a timely manner.

6.0 Materials

- 6.1 SureLine® Odour Control Covers shall have top surface thickness of 4.76mm (min). Deck leg supports shall be 6.35mm thick.
- 6.2 Resins shall be selected from Treadwell's EX-Series® range of resins with chemical formulations as necessary to provide the corrosion resistance, strength and any other physical properties as required.
- 6.3 Glass fibre reinforcements shall be a minimum of half of the material weight.
- 6.4 Materials shall be fire retardant and have a flame spread rating of 25 or less per ASTM E84.
- 6.5 Materials shall exhibit these physical properties (at a minimum):

Tensile Strength	206.8 MPa	ASTM D638
Compressive Strength	206.8 MPa	ASTM D695
Flexural Strength	206.8 MPa	ASTM D790

- 6.6 The top of the tank cover decking shall be flat and non-profiled with a factory applied, anti-slip, UV resistant surface. Typical colour of EcoEX™ SureLine® is grey unless specified with RAL code.

7.0 Acceptable Manufacturer

SureLine® odour control covers shall be manufactured by Treadwell Group Pty Ltd of Australia, EcoEX™ division.

SureLine® Medium Duty Panel

Part: SureLine® Medium Duty Panel

Part Number: ARX-SL040

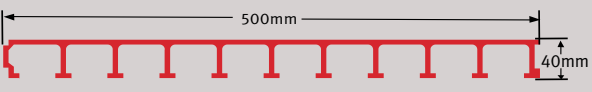
	A_w	2200 mm ²	W_t	10.8 kg/m
		I	1021011 mm ⁴	S
Weight/ lm 10.8kg per lm				

Span (mm)	Maximum Load (kPa)	Deflection (kPa)									
		L/D=100	L/D=120	L/D=150	L/D=180	L/D=220	L/D=250	L/D=300	L/D=350	L/D=400	L/D=500
400	226.60					196.78	173.17	144.31	123.69	108.23	86.59
600	122.33	140.68	117.23	93.78	78.15	63.94	56.27	46.89	40.19	35.17	28.14
800	68.81	61.43	51.19	40.95	34.13	27.92	24.57	20.48	17.55	15.36	12.29
1000	44.04	31.97	26.64	21.31	17.76	14.53	12.79	10.66	9.13	7.99	6.39
1200	30.58	18.67	15.56	12.45	10.37	8.49	7.47	6.22	5.33	4.67	3.73
1400	22.47	11.82	9.85	7.88	6.57	5.37	4.73	3.94	3.38	2.96	2.36
1600	17.20	7.95	6.62	5.30	4.41	3.61	3.18	2.65	2.27	1.99	1.59
1800	13.59	5.59	4.66	3.73	3.11	2.54	2.24	1.86	1.60	1.40	1.12
2000	11.01	4.09	3.40	2.72	2.27	1.86	1.63	1.36	1.17	1.02	0.82
2200	9.10	3.07	2.56	2.05	1.71	1.40	1.23	1.02	0.88	0.77	0.61
2400	7.65	2.37	1.97	1.58	1.32	1.08	0.95	0.79	0.68	0.59	0.47
2600	6.51	1.87	1.55	1.24	1.04	0.85	0.75	0.62	0.53	0.47	0.37
2800	5.62	1.49	1.25	1.00	0.83	0.68	0.60	0.50	0.43	0.37	0.30
3000	4.89	1.22	1.01	0.81	0.68	0.55	0.49	0.41	0.35	0.30	0.24
3200	4.30	1.00	0.84	0.67	0.56	0.46	0.40	0.33	0.29	0.25	0.20

Installation



General

1.0 Scope

- 1.1 Scope of work shall include materials for fibreglass reinforced plastic (FRP) odour control covers including: EcoEX™ SureLine® odour control cover deck panels; ArchitEX™ FRP structural supports, EcoEX™ SureLine® flashing and trim, fasteners and anchors, EcoEX™ SureLine® gaskets.
- 1.2 SureLine® odour control covers shall be designed by Treadwell to be practicably odour secure unless specified otherwise.

2.0 Standards/ Related Documents

- 2.1 The odour control covers shall adhere to the applicable sections of:
 - 2.1.1 ASTM E84 Surface Burning Characteristics Of Building Materials
 - 2.1.2 ASTM D638 Standard Test Method For Tensile Properties Of Plastics
 - 2.1.3 ASTM D695 Standard Test Method For Compressive Properties Of Plastics
 - 2.1.4 ASTM D790 Standard Test Method For Flexural Properties Of Plastics
 - 2.1.5 AS 1170 Structural Design Actions

3.0 Design Criteria

- 3.1 Design Loads
 - 3.1.1 Wind Uplift _____ kPa
 - 3.1.2 Dead Load _____ kPa
 - 3.1.3 Live Loads _____ kPa
- 3.2 Cover Panel Removability
 - 3.2.1 Each SureLine® odour control cover panel shall be removable without having to remove no more than its two adjacent panels.
 - 3.2.2 Each SureLine® odour control cover panel shall be removable vertically and without cutting of a cover component.

4.0 Submittals

- 4.1 Shop drawings shall be submitted by Treadwell (unless provided by the client) displaying clearly material sizes, types, styles, product codes and including types and sizes of fasteners as well as a layout if required.
- 4.2 Technical data and sample pieces can also be submitted if required.

5.0 Quality Assurance

Quality surrounds every aspect of Treadwell's commitment to our superior products and efficiency. Treadwell's quality assurance strictly adheres to the high quality control standards placed to conform to relevant specifications, codes, Australian Standards and contractual requirements in a timely manner.

Products

6.0 Materials

- 6.1 All FRP structural components including decking, beams, and framing shall be manufactured the ArchitEX™ range.
- 6.2 Glass fibre reinforcements shall be minimum 50% of the material weight.
- 6.3 Materials shall be fire retardant with flame spread rating of 25 or less per ASTM E84.
- 6.4 Materials shall exhibit these physical properties (minimum):

Tensile Strength	206.8 MPa	ASTM D638
Compressive Strength	206.8 MPa	ASTM D695
Flexural Strength	206.8 MPa	ASTM D790
Tensile Modulus	20.6 GPa	ASTM D638
Izod Impact (Notched)	1.1 J/mm	ASTM D256
Water Absorption	0.2%	ASTM D570

6.5 SureLine® MD Odour Control Covers

- 6.5.1 Resins shall be selected from Treadwell's EX-Series® range of resins with chemical formulations as necessary to provide the corrosion resistance, strength and any other physical properties as required.
- 6.5.2 Deck panels shall be sealed at side-laps with factory installed, non adhesive, 25.4mm diameter neoprene bulb gasket.
- 6.5.3 Top of SureLine® MD odour control cover decking shall be flat and have an anti-slip, UV resistant surface.
- 6.5.4 Typical colour of EcoEX™ SureLine® MD is grey unless specified with RAL code.

7.0 Acceptable Manufacturer

SureLine® odour control covers shall be manufactured by Treadwell Group Pty Ltd of Australia, EcoEX™ division.

SureLine® Heavy Duty Panel

Part: SureLine® Heavy Duty Panel

Part Number: ARX-SL100

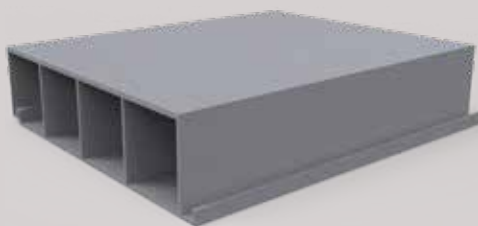
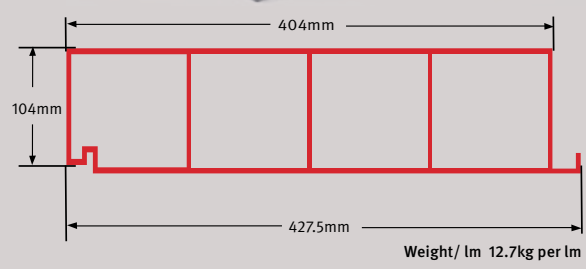
A_w	2080 mm ²	W_t	12.7 kg/m
I	11096613 mm ⁴	S	192449 mm ³

Span (mm)	Maximum Load (kPa)	Deflection (kPa)									
		L/D=100	L/D=120	L/D=150	L/D=180	L/D=220	L/D=250	L/D=300	L/D=350	L/D=400	L/D=500
1000	106.06							105.70	90.60	79.28	63.42
1200	88.38						79.43	66.19	56.74	49.65	39.72
1400	75.76				73.09	59.80	52.63	43.86	37.59	32.89	26.31
1600	66.29			60.82	50.68	41.47	36.49	30.41	26.06	22.81	18.25
1800	58.92		54.71	43.76	36.47	29.84	26.26	21.88	18.76	16.41	13.13
2000	53.03	48.71	40.59	32.47	27.06	22.14	19.48	16.24	13.92	12.18	9.74
2200	48.21	37.09	30.91	24.73	20.61	16.86	14.84	12.36	10.60	9.27	7.42
2400	44.19	28.86	24.05	19.24	16.04	13.12	11.55	9.62	8.25	7.22	5.77
2600	38.86	22.89	19.07	15.26	12.71	10.40	9.15	7.63	6.54	5.72	4.58
2800	33.51	18.44	15.37	12.29	10.25	8.38	7.38	6.15	5.27	4.61	3.69
3000	29.19	15.07	12.56	10.05	8.37	6.85	6.03	5.02	4.31	3.77	3.01
3200	25.65	12.47	10.39	8.32	6.93	5.67	4.99	4.16	3.56	3.12	2.49
3400	22.72	10.44	8.70	6.96	5.80	4.74	4.17	3.48	2.98	2.61	2.09
3600	20.27	8.82	7.35	5.88	4.90	4.01	3.53	2.94	2.52	2.20	1.76
3800	18.19	7.52	6.26	5.01	4.18	3.42	3.01	2.51	2.15	1.88	1.50
4000	16.42	6.46	5.38	4.31	3.59	2.94	2.58	2.15	1.85	1.61	1.29
4200	14.89	5.59	4.66	3.73	3.11	2.54	2.24	1.86	1.60	1.40	1.12
4400	13.57	4.87	4.06	3.25	2.71	2.21	1.95	1.62	1.39	1.22	0.97
4600	12.41	4.27	3.56	2.85	2.37	1.94	1.71	1.42	1.22	1.07	0.85

Installation

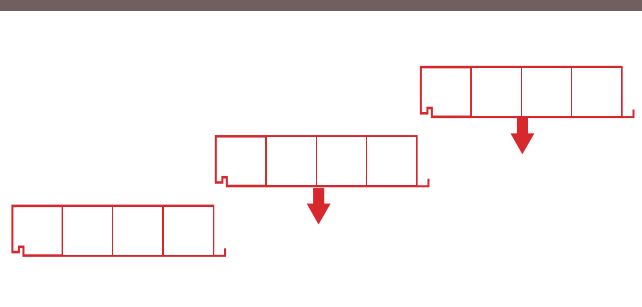

Unique Panel Removal Feature

This allows access to a central panel without having to remove all panels.

General

1.0 Scope

- 1.1 Scope of work shall include materials for fibreglass reinforced plastic (FRP) odour control covers including EcoEX™ SureLine® HD odour control cover deck panels, ArchitEX™ FRP structural supports, EcoEX™ SureLine® HD flashing and trim, fasteners and anchors, EcoEX™ SureLine® HD gaskets.
- 1.2 SureLine® HD odour control covers shall be designed by Treadwell to be practicably odour secure unless specified otherwise.

2.0 Standards/ Related Documents

- 2.1 The odour control covers shall adhere to the applicable sections of:
 - 2.1.1 ASTM E84 Surface Burning Characteristics Of Building Materials
 - 2.1.2 ASTM D256 Standard Test Method For Determining Izod Impact
 - 2.1.3 ASTM D570 Standard Test Method For Water Absorption Of Plastics
 - 2.1.4 ASTM D638 Standard Test Method For Tensile Properties Of Plastics
 - 2.1.5 ASTM D695 Standard Test Method For Compressive Properties Of Plastics
 - 2.1.6 ASTM D790 Standard Test Method For Flexural Properties Of Plastics
 - 2.1.7 AS 1170 Structural Design Actions

3.0 Design Criteria

- 3.1 Design Loads
 - 3.1.1 Wind Uplift _____ kPa
 - 3.1.2 Dead Load _____ kPa
 - 3.1.3 Live Load _____ kPa
- 3.2 Cover Panel Removability
 - 3.2.1 Each SureLine® HD odour control cover panel shall be removable without having to remove no more than its two adjacent panels.
 - 3.2.2 Each SureLine® HD odour control cover panel shall be removable vertically and without cutting of a cover component.

4.0 Submittals

- 4.1 Shop drawings shall be submitted by Treadwell (unless provided by the client) displaying clearly material sizes, types, styles, product codes and including types and sizes of fasteners as well as a layout if required.
- 4.2 Technical data and sample pieces can also be submitted if required.

5.0 Quality Assurance

Quality surrounds every aspect of Treadwell's commitment to our superior products and efficiency. Treadwell's quality assurance strictly adheres to the high quality control standards placed to conform to relevant specifications, codes, Australian Standards and contractual requirements in a timely manner.

Products

6.0 Materials

- 6.1 All FRP structural components including decking, beams, and framing shall be manufactured the ArchitEX™ range.
- 6.2 Glass fibre reinforcements shall be minimum 50% of the material weight.
- 6.3 Materials shall be fire retardant with flame spread rating of 25 or less per ASTM E84.
- 6.4 Materials shall exhibit these physical properties (minimum):

Tensile Strength	206.8 MPa	ASTM D638
Compressive Strength	206.8 MPa	ASTM D695
Flexural Strength	206.8 MPa	ASTM D790
Tensile Modulus	20.6 GPa	ASTM D638
Izod Impact (Notched)	1.1 J/mm	ASTM D256
Water Absorption	0.2%	ASTM D570

6.5 SureLine® HD Odour Control Covers

- 6.5.1 Resins shall be selected from Treadwell's EX-Series® range of resins with chemical formulations as necessary to provide the corrosion resistance, strength and any other physical properties as required.
- 6.5.2 Deck panels shall be sealed at side-laps with factory installed, non adhesive, 25.4mm diameter neoprene bulb gasket.
- 6.5.3 Top of SureLine® HD odour control cover decking shall be flat and have an anti-slip, UV resistant surface.
- 6.5.4 Typical colour of EcoEX™ SureLine® HD is grey unless specified with RAL code.

7.0 Acceptable Manufacturer

SureLine® HD odour control covers shall be manufactured by Treadwell Group Pty Ltd of Australia, EcoEX™ division.

Load Span Table

Maximum Allowable Load - Safety Factor = 2.5



Span(m)	Uniform Live Load (kPa)	Concentrated Load (kg)
	L/D = 120	L/D = 180
6.10m	1.00	140
5.50m	1.50	173
4.90m	2.25	217
4.30m	3.50	282
3.70m	5.75	375

UnidEX® FRP Deck Panel

Part: UnidEX®40mm thick decking, 120mm bar width and 6mm gap

Part Number: ARX-UN04012006

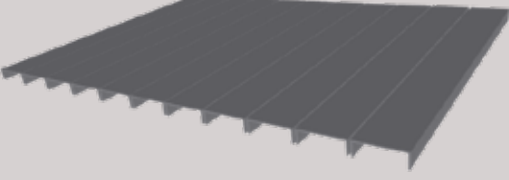
Properties per Bar

	A_w	400mm ²	W_t	17 kg/m
		I	125400mm ⁴	S

Span (mm)	Maximum Load (KPa)	Deflection (kPa)									
		L/D=100	L/D=120	L/D=150	L/D=180	L/D=220	L/D=250	L/D=300	L/D=350	L/D=400	L/D=500
400	44.59										42.60
600	19.82								19.19	16.79	13.43
800	11.15							9.66	8.28	7.24	5.80
1000	7.13					6.82	6.00	5.00	4.28	3.75	3.00
1200	4.95				4.85	3.97	3.49	2.91	2.49	2.18	1.75
1400	3.64				3.06	2.51	2.21	1.84	1.58	1.38	1.10
1600	2.79			2.47	2.06	1.68	1.48	1.23	1.06	0.93	0.74
1800	2.20		2.17	1.74	1.45	1.18	1.04	0.87	0.74	0.65	0.52
2000	1.78	1.90	1.58	1.27	1.06	0.86	0.76	0.63	0.54	0.48	0.38

TreadSLAB®

TreadSLAB® is an immensely versatile profile which combines lightweight and inherent strength to provide a durable product with a variety of surface textures and a customisable range of colours. Through the selection of the appropriate resin system, the user can create components that will meet the most demanding of specifications.

Pultruded through a die, TreadSLAB® outperforms with an impressive strength to weight ratio to produce a composite flooring structure that is strong, durable, corrosion resistant and boasts low maintenance on an anti-slip surface.

Benefits

- High strength
- Light weight
- Dimensional stability
- Corrosion, chemical, electrical resistance
- Low tooling/installation cost
- Long life
- Favourable performance/lifecycle cost basis versus traditional materials

TreadSLAB® easily outperforms traditional materials in terms of performance/ lifecycle costs.

TreadSLAB® 45

Part: TreadSLAB® 45mm Thick Decking, 48mm Web Distance, 4.5mm Flange Thickness and 3.5mm Web Thickness

Part Number: ARX-TS04504805

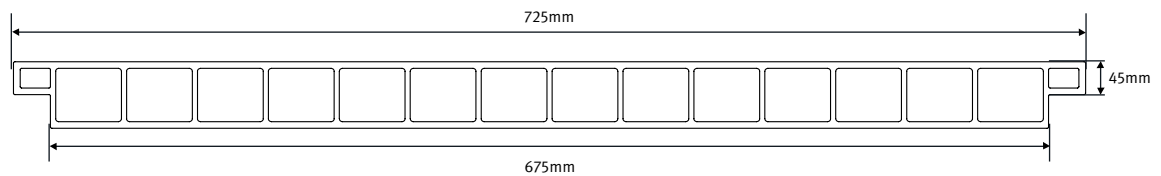

Panel Size (mm)			Surface Type	Weight Per Square Metre (kg/m ²)
Thickness	Standard Length	Width		
45mm Top	3660	725	Top Grit	25
45mm Bottom	3660	675	Bottom Grit	

TreadSLAB® 50

Part: TreadSLAB® 50mm Thick Decking, 55mm Web Distance, 6mm Flange Thickness and 9mm Web Thickness

Part Number: ARX-TS05005506

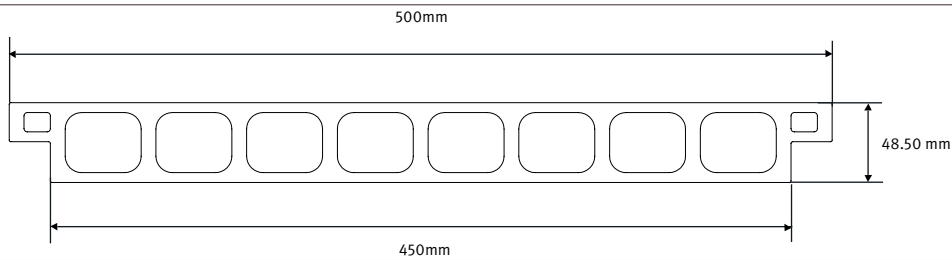

Panel Size (mm)			Surface Type	Weight Per Square Metre (kg/m ²)
Thickness	Standard Length	Width		
50mm Top	3660	500	Top Grit	36.44
50mm Bottom	3660	450	Bottom Grit	

TreadSLAB® 100

Part: TreadSLAB® 100mm Thick Decking, 60mm Web Distance, 13mm Flange Thickness and 12mm Web Thickness

Part Number: ARX-TS10006013

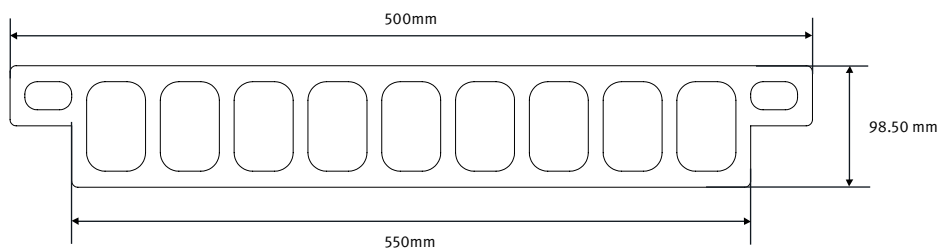

Panel Size (mm)			Surface Type	Weight Per Square Metre (kg/m ²)
Thickness	Standard Length	Width		
100mm Top	3660	650	Top Grit	92.17
100mm Bottom	3660	550	Bottom Grit	

Part: TreadSLAB® 47.5mm Thick Decking, 74.6mm Web Distance and 6.4mm Thickness

Part Number: ARX-TS04807506

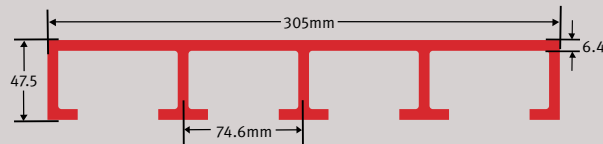

Part: TreadSLAB® 54mm Thick Decking, 100mm Web Distance and 5mm Thickness

Part Number: ARX-TS05410005

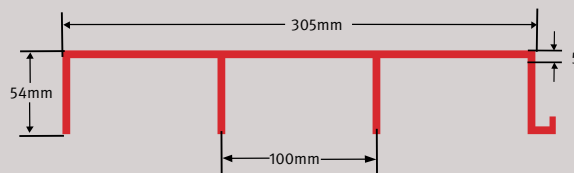

Part: TreadSLAB® 83mm Thick Decking, 49.7mm Web Distance and 6.4mm Thickness

Part Number: ARX-TS08305006

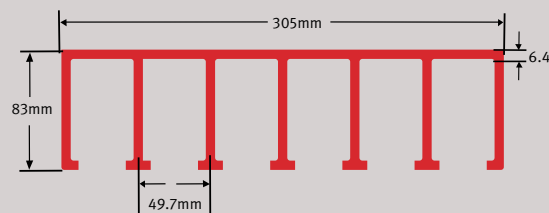

Chemical Resistance Guide

When choosing a resin type for your application, we highly recommend you consult us to ensure important details such as corrosion, environment, temperature and requirements are taken into account. Dependent on these particulars, we will determine which resin system should be utilised for optimum performance over time.

V-Series® Vinylester Resin System is a high quality and is the most chemical resistant system offered in the industry and has been developed for use in environments where fibreglass/FRP products are subject to frequent and direct contact with the harshest of chemicals: including a broad range of acids and caustics. This system has a flame spread of 25 or less.

I-Series® is a premium Isophthalic Resin System. This system provides an intermediate level of chemical resistance and is the

correct choice for areas subjected to splash and spill contact with harsh chemicals. This system is an excellent general-purpose resin and is a more favourably priced alternative to the vinyl ester system. This system has a flame spread of 25 or less.

O-Series® is an architectural grade Polyester Resin System with a moderate chemical resistance. O-Series® is a good choice for commercial or light industrial applications, especially in areas where moisture is prevalent. O-Series® is often utilized for public infrastructure applications where it has been proven to outperform traditional timber decking products. It should be noted that Treadwell does not recommend O-Series for water and waste water treatment applications.

Treadwell also offers resin systems that are suitable for use in contact with potable drinking water and compliant with AS4020.

Chemical Resistance Guide

Information contained in this guide is based on data collected from several years of actual industrial applications. Recommendations are based on conservative evaluations of the changes which occur in certain properties of replicate laminates after exposures of one year or longer, both in the laboratory and the field.

Temperatures are neither the minimum nor the maximum but represent standard test conditions (Room Temperature & 70°C). The products may be suitable at higher temperatures but individual test data should be required to establish such suitability. Contact Treadwell for any special applications that you may have.

The recommendations (• : resistant: – :not resistant) contained in this specification sheet are made without guarantee or representation as to results. We suggest that you evaluate these recommendations and suggestions in your own laboratory or actual field trial prior to use. Our responsibility for claims arising from breach of warranty, negligence, or otherwise is limited to the purchase price of the material.

Chemical	I-Series®		V-Series®	
	Room Temp	70°C	Room Temp	70°C
Acetaldehyde	—	—	—	—
Acetic Acid 0-25%	•	•	•	•
Acetic Acid 25-50%	•	—	•	•
Acetic Anhydride	—	—	—	—
Acetone	—	—	—	—
Acrylonitrile	—	—	—	—
Alcohol, Butyl	—	—	•	—
Alcohol, Ethyl 10%	—	—	•	66
Alcohol, Ethyl 100%	—	—	•	—
Alcohol, Isopropyl 10%	—	—	•	66
Alcohol, Isopropyl 100%	—	—	•	—
Alcohol, Methyl 10%	—	—	•	66
Alcohol, Methyl 100%	—	—	—	—
Alcohol, Methyl Isobutyl	—	—	•	66
Alcohol, Secondary Butyl	—	—	•	66
Aluminium	•	•	•	•
Aluminium Chloride	•	•	•	•
Aluminium Hydroxide	•	—	•	49
Aluminium Nitrate	•	•	•	•

Chemical	I-Series®		V-Series®	
	Room Temp	70°C	Room Temp	70°C
Aluminium Potassium Sulfate	•	•	•	•
Ammonia, Aqueous 0-10%	—	—	•	38
Ammonia, Gas	—	—	•	38
Ammonium Bicarbonate	•	—	•	49
Ammonium Bisulfite	—	—	•	49
Ammonium Carbonate	—	—	•	49
Ammonium Citrate	•	—	•	49
Ammonium Fluoride	—	—	•	49
Ammonium Hydroxide 5%	•	—	•	49
Ammonium Hydroxide 10%	•	—	•	49
Ammonium Hydroxide 20%	—	—	•	49
Ammonium Nitrate	•	•	•	49
Ammonium Persulfate	—	—	•	49
Ammonium Phosphate	—	—	•	49
Ammonium Sulfate	•	•	•	•
Arsenious Sulfate	•	—	•	•
O-Benzoyl Benzoic Acid	—	—	•	•
Barium Carbonate	•	—	•	•
Barium Chloride	•	—	•	•

Chemical Resistance Guide

Chemical	I-Series®		V-Series®	
	Room Temp	70°C	Room Temp	70°C
Barium Hydroxide	—	—	•	49
Barium Sulfate	•	•	•	•
Barium Sulfide	—	—	•	•
Beer	•	—	•	49
Benzene	—	—	—	—
5% Benzene in Kerosene	•	—	•	•
Benzene Sulfonic Acid	•	•	•	•
Benzoic Acid	•	—	•	•
Benzyl Alcohol	—	—	•	—
Benzyl Chloride	—	—	—	—
Brass Plating Solution:				
– 3% Copper Cyanide	—	—	•	•
– 6% Sodium Cyanide	—	—	•	•
– 1% Zinc Cyanide	—	—	•	•
– 3% Sodium Carbonate	—	—	•	•
Butyl Acetate	—	—	—	—
Butyric Acid 0-50%	•	—	•	•
Butylene Glycol	•	•	•	•
Cadmium Chloride	•	—	•	•
Cadmium Cyanide Plating Soln:				
– 3% Cadmium Oxide	—	—	•	49
– 6% Sodium Cyanide	—	—	•	49
– 1% Caustic Soda	—	—	•	49
Calcium Bisulfate	•	•	•	•
Calcium Carbonate	•	—	•	•
Calcium Chlorate	•	•	•	•
Calcium Chloride	•	•	•	•
Calcium Hydroxide	•	—	•	49
Calcium Hypochlorite	•	—	•	49
Calcium Nitrate	•	•	•	•
Calcium Sulfate	•	•	•	•
Calcium Sulfite	•	•	•	•
Caprylic Acid	•	—	•	•
Carbon Dioxide	•	•	•	•
Glycerine	•	•	•	•
Glycol, Ethylene	•	•	•	•
Glycol, Propylene	•	•	•	•
Glycolic Acid	•	—	•	•
Gold Plating Solution:				
– 63% Potassium Ferrocyanide	—	—	•	•
– 2% Potassium Gold Cyanide	—	—	•	•
– 8% Sodium Cyanide	—	—	•	•
Heptane	•	—	•	•
Hexane	•	—	•	•
Hexylene Glycol	•	•	•	•
Hydraulic Fluid	•	—	•	•

Chemical	I-Series®		V-Series®	
	Room Temp	70°C	Room Temp	70°C
Hydrobromic Acid 0-25%	•	—	•	•
Hydrochloric Acid 0-37%	•	—	•	•
Hydrocyanic Acid	•	—	•	•
Hydrofluoric Acid 10%	—	—	•	—
Hydrofluosilicic Acid, 10%	—	—	•	•
Hydrogen Bromide, Wet Gas	—	—	•	•
Hydrogen Chloride, Dry Gas	—	—	•	•
Hydrogen Chloride, Wet Gas	—	—	•	•
Hydrogen Peroxide	—	—	•	49
Hydrogen Sulfide, Dry	•	—	•	•
Hydrogen Sulfide, Aqueous	•	—	—	•
Hydrogen Fluoride, Vapour	—	—	•	•
Hydrosulfite Bleach	—	—	•	49
Hydrochloric Acid 0-10%	—	—	—	—
Iron Plating Solution:				
– 45% Fecl: 15% Cacl	—	—	•	•
– 20% Fecl: 11% (Nh4)2 So4	—	—	•	•
Iron And Steel Claeaning Bath:				
–9% Hydrochloric: 23% Sulfuric	—	—	•	•
Isopropyl Amine	—	—	•	38
Isopropyl Palmitate	•	•	•	•
Jet Fuel	•	—	•	•
Kerosene	•	—	•	•
Lactic Acid	•	—	•	•
Lauroryl Chloride	—	—	•	•
Lauric Acid	•	—	•	•
Lead Acetate	•	—	•	•
Lead Chloride	•	—	•	•
Lead Nitrate	•	—	•	•
Lead Plating Solution:				
–.8% Fluoboric, 0.4% Boric Acid	—	—	•	•
Levulinic Acid	•	—	•	•
Linseed Oil	•	•	•	•
Lithium Bromide	•	•	•	•
Lithium Sulfate	•	•	•	•
Magnesium Bisulfite	•	—	•	•
Magnesium Carbonate	•	—	•	•
Magnesium Chloride	•	•	•	•
Magnesium Hydroxide	—	—	•	60
Magnesium Nitrate	•	—	•	•
Magnesium Sulfate	•	•	•	•
Maleic Acid	•	•	•	•
Mercuric Chloride	•	—	•	•
Mercurous Chloride	•	—	•	•
Methylene Chloride	—	—	—	—
Methyl Ethyl Ketone	—	—	—	—

Chemical Resistance Guide

Chemical	I-Series®		V-Series®	
	Room Temp	70°C	Room Temp	70°C
Methyl Isobutyl Carbitol	—	—	—	—
Methanol (See Alcohol)	•	—	•	•
Methyl Isobutyl Ketone	—	—	—	—
Methyl Styrene	—	—	—	—
Mineral Oils	•	•	•	•
Molybdenum Disulfide	•	—	•	•
Monochloro Acetic Acid	—	—	—	—
Monoethanolamine	—	—	—	—
Motor Oil	•	•	•	•
Myristic Acid	—	—	•	•
Naptha	•	•	•	•
Napthalene	•	—	•	•
Nickel Chloride	•	•	•	•
Nickel Nitrate	•	•	•	•
Nickel Plating:				
– 8% Lead, 0.8% Flouboric Acid	—	—	•	•
– 0.4% Boric Acid	—	—	•	•
Nickel Plating:				
– 11% Nickel Sulfate	•	—	•	•
– 2% Nickel Chloride	•	—	•	•
– 1% Boric Acid	•	—	•	•
Nickel Plating:				
– 44% Nickel Sulfate	•	—	•	•
– 4% Ammonium Chloride	•	—	•	•
– 4% Boric Acid	•	—	•	•
Nickel Sulfate	•	•	•	•
Nitric Acid 0-5%	•	•	•	•
Nitric Acid 20%	—	—	•	49
Nitric Acid Fumes	—	—	—	—
Nibrobenzene	—	—	—	—
Octanoci Acid	•	—	•	•
Oil, Sour Crude	•	•	•	•
Oil, Sweet Crude	•	•	•	•
Oleic Acid	•	•	•	•
Oleum (Fuming Sulfuric)	—	—	—	—
Olive Oil	•	•	•	•
Oxalic Acid	•	•	•	•
Peroxide Bleach:				
– 25% Peroxide 95%	•	•	•	•
– 0.025% Epsom Salts	•	•	•	•
– 5% Sodium Silicate 42.Be	•	•	•	•
– 1.4% Sulfuric Acid 66.Be	•	•	•	•
Phenol	—	—	—	—
Phenol Sulfonic Acid	—	—	—	—
Phosphoric Acid	•	•	•	•
Phosphoric Acid Fumes	•	•	•	•

Chemical	I-Series®		V-Series®	
	Room Temp	70°C	Room Temp	70°C
Phosphorous Pentoxide	•	•	•	•
Phosphorous Trichloride	—	—	—	—
Phthalic Acid	•	•	•	•
Pickling Acids(Sulfuric & Hydrochloric)	•	•	•	•
Picric Acid, Alcoholic	—	—	—	—
Polyvinyl Acetate Latex	•	—	•	•
Polyvinyl Alcohol	•	—	•	38
Polyvinyl Chloride Latex W/35(Parts Dop)	—	—	•	49
Potassium Aluminium Sulfate	•	•	•	•
Potassium Bicarbonate	•	—	•	60
Potassium Bromide	•	—	•	38
Potassium Carbonate	•	—	•	60
Potassium Chloride	•	•	•	•
Potassium Dichromate	•	—	•	60
Potassium Ferricyanide	•	•	•	•
Potassium Ferrocyanide	•	•	•	•
Potassium Hydroxide	—	—	•	66
Potassium Nitrate	•	•	•	•
Potassium Permanganate	•	—	•	60
Potassium Persulfate	•	—	•	•
Potassium Sulfate	•	•	•	•
Propionic Acid 1-50%	—	—	•	49
Propionic Acid 50-100%	—	—	—	—
Propylene Glycol	•	•	•	•
Pulp Paper Mill Effluent	•	—	•	•
Pyridine	—	—	—	—
Salicylic Acid	—	—	•	60
Sebacic Acid	—	—	•	•
Selenious Acid	—	—	•	•
Silver Nitrate	•	•	•	•
Silver Plating Solution:				
– 44% Silver Cyanide	—	—	•	•
– 7% Potassium Cyanide	—	—	•	•
– 5% Sodium Cyanide	—	—	•	•
– 2% Potassium Carbonate	—	—	•	•
Soaps	•	—	•	•
Sodium Acetate	•	—	•	•
Sodium Benzoate	•	—	•	•
Sodium Bicarbonate	•	•	•	•
Sodium Bifluoride	•	—	•	49
Sodium Bisulfate	•	•	•	•
Sodium Bisulfite	•	•	•	•
Sodium Bromate	•	•	•	60
Sodium Bromide	•	•	•	•
Sodium Carbonate 0-25%	•	—	•	•
Sodium Chlorate	•	—	•	•

Chemical Resistance Guide

Chemical	I-Series®		V-Series®	
	Room Temp	70°C	Room Temp	70°C
Sodium Chloride	•	•	•	•
Sodium Chlorite	•	—	•	•
Sodium Chromite	•	•	•	•
Sodium Cyanide	•	—	•	•
Sodium Dichromate	•	•	•	•
Sodium Di-Phosphate	•	•	•	•
Sodium Ferricyanide	•	•	•	•
Sodium Fluoride	•	—	•	49
Sodium Fluoro Silicate	—	—	•	49
Sodium Hexametaphosphates	—	—	•	38
Sodium Hydroxide 0-5%	—	—	•	66
Sodium Hydroxide 5-25%	—	—	•	66
Sodium Hydroxide 50%	—	—	•	66
Sodium Hydrosulfide	•	—	•	•
Sodium Hypochlorite	•	—	•	66
Sodium Lauryl Sulfate	•	•	•	•
Sodium Mono-Phosphate	•	•	•	•
Sodium Nitrate	•	•	•	•
Sodium Silicate	•	—	•	•
Sodium Sulfate	•	•	•	•
Sodium Sulfide	•	—	•	•
Sodium Sulfite	•	—	•	•
Sodium Tetra Borate	•	•	•	•
Sodium Thiocyanate	—	—	•	•
Sodium Thiosulfate	•	—	•	•
Sodium Tripolyphosphate	•	—	•	•
Sodium Xylene Sulfonate	•	—	•	•
Sodium Solutions	•	—	•	•
Sodium Crude Oil	•	•	•	•
Soya Oil	•	•	•	•
Stannic Chloride	•	•	•	•
Stannous Chloride	•	•	•	•
Stearic Acid	•	•	•	•
Styrene	—	—	—	—
Sugar, Beet And Cane Liquor	•	—	•	•
Sugar, Sucrose	•	•	•	•
Sulfamic Acid	•	—	•	•
Sulfanilic Acid	•	—	•	•
Sulfated Detergents	•	—	•	•
Sulfur Dioxide, Dry Or Wet	—	—	•	•
Sulfur Trioxide/Air	—	—	•	•
Sulfuric Acid 0-30%	•	•	•	•
Sulfuric Acid 30-50%	—	—	•	•
Sulfuric Acid 50-70%	—	—	•	49
Sulfurous Acid	—	—	•	38
Superphosphoric Acid (76% P2 O5)	•	—	•	•

Chemical	I-Series®		V-Series®	
	Room Temp	70°C	Room Temp	70°C
Tall Oil	•	—	•	60
Tannic Acid	•	—	•	66
Tartaric Acid	•	•	•	•
Thionyl Chloride	—	—	—	—
Tin Plating:				
– 18% Stannous Fluorborate	—	—	•	•
– 7% Tin	—	—	•	•
– 9% Fluoroboric Acid	—	—	•	•
– 2% Boric Acid	—	—	•	•
Toluene	—	—	—	—
Toluene Sulfonic Acid	—	—	•	•
Transformer Oils:				
– Mineral Oil Types	•	•	•	•
– Chloro-Phenyl Types)	•	•	•	•
Trichlor Acetic Acid	•	—	•	•
Trichlorethylene	—	—	—	—
Trichloropenol	—	—	—	—
Tricresyl Phosphate	—	—	•	49
Tridecylbenzene Sulfonate	•	—	•	•
Trisodium Phosphate	•	—	•	•
Turpentine	—	—	•	38
Urea	—	—	•	38
Vegetable Oils	•	•	•	•
Vinegar	•	•	•	•
Vinyl Acetate	—	—	—	—
Water:				
– Deionised	—	—	—	—
– Demineralised	•	•	•	•
– Distilled	•	•	•	•
– Fresh	•	•	•	•
– Salt	•	•	•	•
– Sea	•	•	•	•
White Liquor (Pulp Mill)	•	—	•	•
Xylene	—	—	—	—
Zinc Chlorate	•	•	•	•
Zinc Nitrate	•	•	•	•
Zinc Plating Solution:				
– 9% Zinc Cyanide	—	—	•	49
– 4% Sodium Cyanide	—	—	•	49
–9% Sodium Hydroxide	—	—	•	49
Zinc Plating Solution:				
– (49% Zinc Fluorborate	•	—	•	•
– 5% Ammonium Chloride	•	—	•	•
– 6% Ammonium Fluorborate	•	—	•	•
Zinc Sulfate	•	•	•	•

Martin Place Temporary Walkway

Treadwell was contacted to assist with providing a product that could be used as a lightweight anti-slip solution as a walking surface on the temporary walkway gantry at Martin Place Sydney. The walkway gantry runs between Elizabeth St. and Castlereagh St. To date, it has been installed for over 12 months and has a daily pedestrian traffic volume exceeding 36,000 people.

Project Challenges

- The material was required to be lightweight and easily site adjustable.
- Needed to have an acceptable anti-slip surface that met the requirements of a P5 rating.
- It had to be non-corrosive and non-conductive.

PROJECT INFORMATION

Project Category:	Rail Infrastructure
Scope of Work:	To provide and anti-slip light weight walkway access
Treadwell Products:	EcoEX™ SureLine® Heavy Duty panels
Value:	\$ 200,000

Treadwell Solution:



1

Treadwell's high performance EcoEX™ SureLine® HD panels are manufactured from premium grade, corrosion-resistant fibreglass resins.

2

The panels for this project were designed and customized to meet live load requirements.

3

FRP is simply fabricated and modified on site. This means there is no need for any hot works permit.

4

Being lightweight and easy to install, FRP is very manageable during construction.

5

Given the nature of FRP, any system utilising it is virtually maintenance free, thus keeping maintenance costs as low as possible.

Caulfield to Dandenong Level Crossing Removal

Caulfield to Dandenong Level Crossing Removal

Melbourne's busiest rail line underwent a transformation that saw the removal of nine dangerous and congested level crossings, to be replaced by an elevated rail design. This elevated rail is able to carry both passenger and freight trains. As part of these new stations, it was decided that FRP access structures would be included in the construction of the new stations as well as the rail track.

Treadwell was engaged to provide the safety egress, access platforms and the central walkway between the rail tracks.

Project Challenges

- Decking for the central walkway had to be easily remove for maintenance access.
- Steppers had to be non-slip, and maintain structural integrity while in permanent outdoor exposure.
- Products had to be installed without the use of heavy machinery.

PROJECT INFORMATION

Project Category:	Rail Infrastructure
Scope of Work:	Design & supply FRP grating and decking
Treadwell Products:	ACCESS SYSTEMS GratEX® FRP Mini Mesh grating EcoEX™ SureLine® Heavy Duty FRP panels

Treadwell Solution:



1

EcoEX™ SureLine® Heavy Duty FRP panels are constructed in a way that allows easy removal of panels whenever access is required.

2

The FRP grating and decking products have an anti-slip surface for greater user safety.

3

Treadwell's FRP products are constructed from premium resins that include corrosion resistant properties and UV inhibitors, making it ideal for this outdoor application.

4

FRP is simply fabricated and modified on site. This means there is no need for any hot works permit.

5

Being lightweight and easy to install, FRP is very manageable during construction.

6

Given the nature of FRP, any system utilising it is virtually maintenance free, keeping maintenance costs to a minimum.

NEPA Rosanna Station Walkway

As part of the rail infrastructure project in Victoria, a brand-new Rosanna rail station was constructed. Built over six weeks, with around 1,000 people working around the clock, this station was operational months ahead of schedule. As a result of this new station, traffic bottlenecks have been greatly reduced, and motorists have been able to travel freely and safely.

Treadwell was engaged to provide the FRP panels used in the passenger walkways and platforms.

Project Challenges

- Selected material had to maintain anti-slip properties regardless of weather conditions, for user safety.
- The decking panels had to be easily removed, to access the covered infrastructure for maintenance requirements.
- Selected material had to be able to handle high weight loading to accommodate heavy foot traffic.

PROJECT INFORMATION

Project Category:	Rail Infrastructure
Scope of Work:	Supply FRP decking
Treadwell Products:	EcoEX™ TreadSLAB® FRP panels

Treadwell Solution:



1 Treadwell's EcoEX™ TreadSLAB® FRP panels are constructed with an anti-slip surface, with corrosion resistant properties, making it ideal for this outdoor application.

2 These panels are lightweight for easy installation and isolated panels can be removed for maintenance requirements.

3 EcoEX™ panels are constructed to withstand high weight loading.

4 FRP is simply fabricated and modified on site. This means there is no need for any hot works permit.

5 Being lightweight and easy to install, FRP is very manageable during construction.

6 Given the nature of FRP, any system utilizing it is virtually maintenance free, keeping maintenance costs to a minimum.



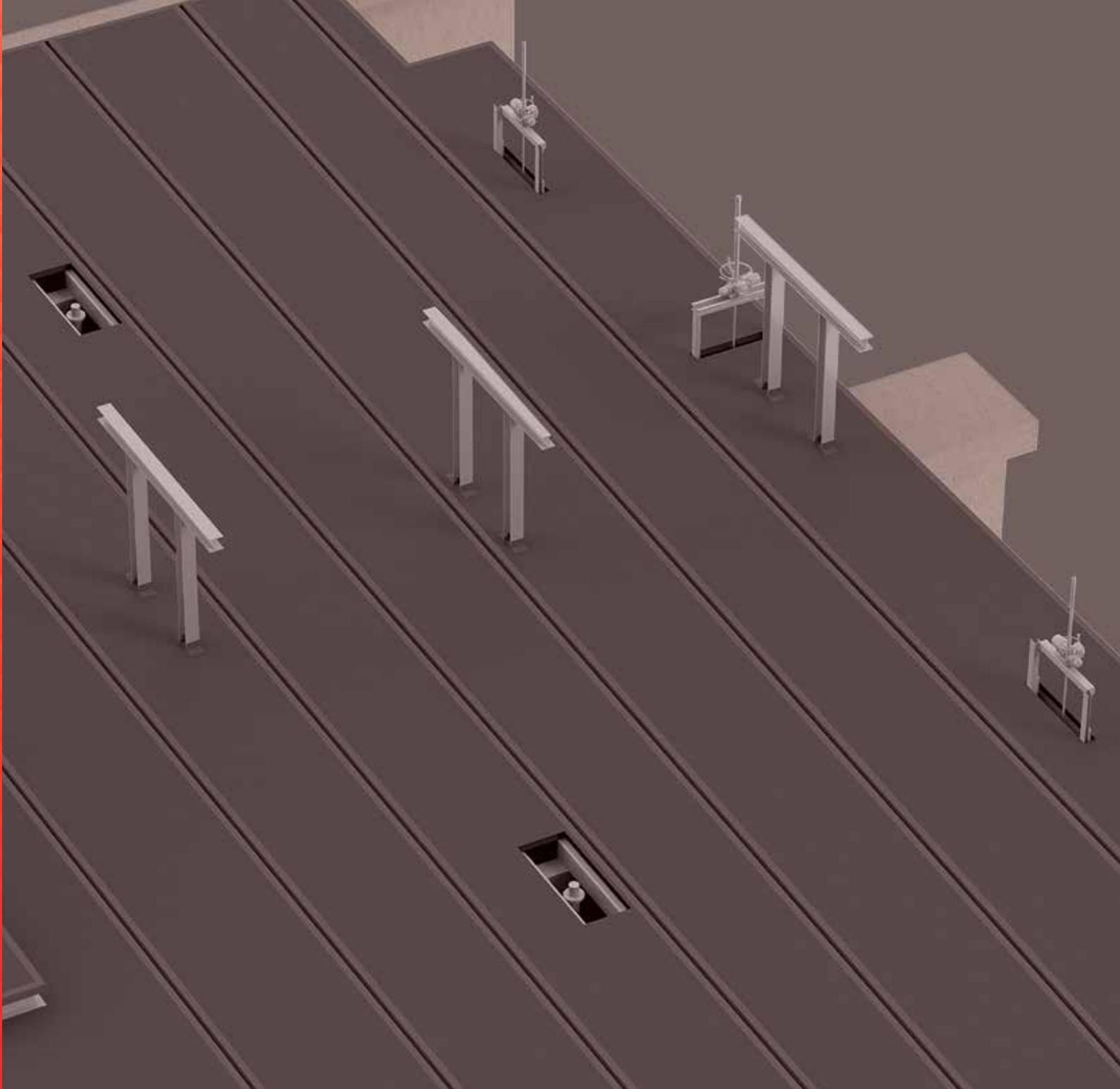
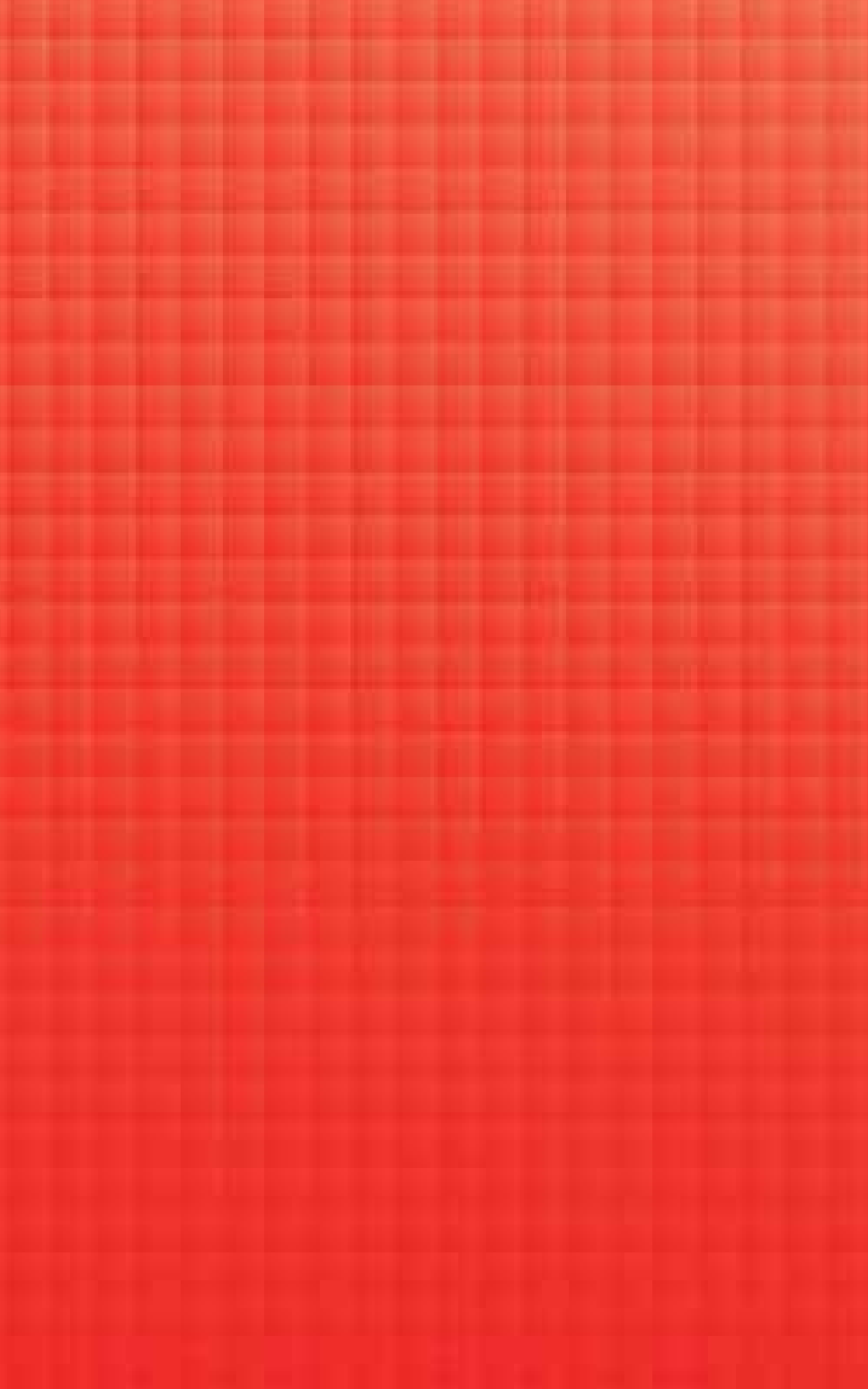

TREADWELL

Treadwell brands mentioned in this document are all registered brands of Treadwell Group Pty Ltd. All pictures and information are supplied as a guide only. The complete range of Treadwell products are developed, refined, made to meet and exceed stringent specifications for the worldwide market.

Important Note: Sales of products are subject to our Terms and Conditions which are available upon request. All specifications and photos are a guide only and are subject to change without notice. Please ring to confirm details. Treadwell products stated only comply with relevant standards mentioned within this publication when installed and used as they are designed to be.

